

5.18 Data and Voice Distribution

This document provides information on the University of Calgary structured cabling practices, standards, and components. All cabling projects are required to follow these standards and practices to ensure that the University structured cabling system(s) can support new applications that require higher speeds and increased reliability.

Client requirements will be examined to determine the best solution for each project and/or Program, in consultation with the UofC IT Department and Facilities Management.

Standards outlined here follow the EIA, TIA, and CSA standards for commercial buildings and BiCSi best practice recommendations. Relevant national electrical codes are always to be followed.

5.18.1 General Introduction

1. Standards outlined here follow the EIA, TIA, and CSA standards for commercial buildings and latest BiCSi best practice recommendations. Relevant national electrical codes are always to be followed

5.18.2 Cabling Systems

1. The U of C follows the TIA/EIA-568-B cabling standards with T568B pin pair assignments. Each project has to be evaluated to determine the copper station cabling to be used. Standard practice is shown below
 - a. Once a building has a manufacturer presence, the whole building will remain with that manufacturer for that generation of cabling system
 - b. Approved copper cable manufacturers include Belden, Commscope, and Panduit
New buildings will be open for quotes using all approved copper cable manufacturers and our approved Cat 6A copper cabling solutions
 - c. Projects in older buildings are to be evaluated by IT Network Engineering to determine if cable plant renewals are required
 - d. Belden is the only manufacturer of Cat 6 cabling to be used if the cable plant is NOT upgraded to Cat 6A
 - e. Acceptable Belden Cat 6 cabling and components are specified in section 5.18.12
 - I. All material on the above mentioned system is to be supplied/installed/certified by the Electrical Contractor (EC)
 - f. Acceptable Cat 6A cabling and components are specified in section 5.18.12
 - I. A given project will only use cable components from one manufacturer
 - II. All material on any of the above mentioned systems are to be supplied/installed/certified by the Electrical Contractor (EC)

- g. Contractors are required to be manufacturer certified in the cabling solution being installed for any and ALL University of Calgary approved manufactures structured cabling systems
- 2. The University of Calgary has standardized on Corning fiber solutions for all in building fiber and campus backbone fiber panel products – as well as for all ‘Passive Optical Network’ (PON) based in-building systems. Cabling will be specified for each project depending on requirements
 - a. Please confirm and review with Network Engineering to finalize on fiber types (i.e. single-mode LC-UPC connectors (building to building); single-mode SC-APC connectors (PON systems); multi mode LC-UPC connectors (in-building riser vertical))
 - I. All material for any of the above mentioned systems, in these reviews and coordination’s, are to be supplied/installed/certified by the Electrical Contractor (EC)
 - b. Outside fiber plant
 - I. **See section 5.18.15: Appendix C (Installation Standards for Fiber Duct)**
- 3. Copper phone cables, connectors, and enclosures
 - a. Backbone and riser cables are to be NORDX/CDT twenty-four (24) AWG ARMM/ATMM multi-conductor that conforms to CSA Standard T529-M91, Section 10.3.1. Or a compatible product approved by the University of Calgary Voice Services department
 - b. Communications Technology PIC Aerial Closure kits
 - c. 3M Telecom Systems MS2 Termination modules
 - d. Typical 200 pair required to building entrance

5.18.3 U of C Wireless

- 1. The U of C wireless system must be installed in all new buildings and renovations.
 - a. U of C wireless access points are procured and supplied by the University of Calgary IT Facilities Intake Team
 - I. Installation will be coordinated by the IT Facilities Intake Team
 - II. Costs for wireless access points and cabling are to be carried under the cost of the project
 - b. Network Engineering are responsible for the wireless designs on all projects and will provide AP locations in consultation with the project teams
- 2. Generally, one AP is installed for every 1200 square feet, or for each 30 occupants within specified spaces at two connected devices per occupant
 - a. Usage density, floor plans, and obstructions all influence AP placement so Network Engineering will provide placement recommendations based on site surveys and heat mapping simulations

- b. Multiple revisions for the wireless design will result should building materials and floor plans change through the Detailed Design phase
3. Certain types of research or other activities may produce radio interference with wireless devices. Any anticipated radio interference sources shall be discussed with Network Engineering before project completion
4. All AP's are to be mounted below T-bar/Drywall ceilings. In open ceiling space, AP's must be mounted below mechanical and structural obstructions
5. AP's are to be installed away from large metal gratings, or materials that reflect radio transmissions
6. AP enclosures can be purchased by IT to mask access points

5.18.4 Facility Requirements

1. Main Riser
 - a. The primary communications room (Main Distribution Frame of MDF for short) of the building should be located close to the building service entrance
 - I. Subsequent telecom rooms (Intermediate Distribution Frame or IDF for short) must be planned for centralized locations due to distance limitations of copper cabling systems (90 meters)
In PON based systems same centralized locations should be adhered to for centralized composite cabling requirements (power over fiber), where applicable
Secondary acceptable PON based power option for edge devices is to have dedicated electrical receptacles at each terminal location.
 - b. A minimum of five (5) 100 mm ducts or a 300 mm x 100 mm tray is required from the service entrance of the building to the communications room. The duct/tray shall originate to the existing low voltage tray in the service tunnel and terminate at the backboard
 - c. Sweep 90 degree bends are to be installed to facilitate pulling of PIC-S backbone cable, home run data cables, and fiber-optic cable
 - d. The main building communications room shall be planned exclusively for telecommunications support. Main building communication rooms are not to include:
 - I. Building electrical
 - II. Security and Card access
 - III. Mechanical distribution systems
 - IV. Other low voltage sub-systems
 - e. The floor of the communications rooms shall, at minimum, be concrete sealed to reduce dust. Door seals or sweeps are required as well to reduce the collection of dust and debris in the communications room



- f. We recommend that the main communications room (MDF) be a minimum of 4 m x 4 m unobstructed by door swing (see section 5.18.5 for typical room layout and sizing information)
- g. Communications riser rooms shall be vertically aligned (where practical) with the primary communications room, riser facilities
 - l. Where more than one riser stack might be required, cable-tray and /or EMT shall be provided from the communications rooms to each remote riser system
- h. All cable-trays shall be brought to the vicinity of one of the walls without a door. Risers and all other cable-trays and/or EMT's shall be located in the vicinity of the same wall
- i. Three (3) 1,200 mm x 2,400 mm sheets of 20 mm G1S plywood (painted with fire retardant paint – Electrical Grey) shall be mounted, with their longest edge vertical, on the wall noted above
- j. Three (3) dedicated 120 VAC single-phase (20) ampere circuits shall be installed on the rack with quad-outlet boxes. Emergency power and UPS shall be included for these and any communications riser room circuits on the system
 - l. UPS' to be supplied by the University of Calgary IT Department
 - ll. See 'Appendix A' for rack layout standard
- k. Adequate light to allow technicians to work on communications support equipment shall be provided (front side and rear side of racks)
 - l. LED lighting's preferred
- l. There shall be a minimum of 2,400 mm of clearance between the working floor and the lowest ceiling-mounted fixtures (lights, cable-trays, etc.)
- m. The target room temperature shall be 18 C to 24 C (64 F to 75 F). Designers shall keep in mind the fact that many building air handling systems deliver heat during the cold months, and special treatment of the communications room required
 - l. Building cooling/air can be delivered into the MDF/IDF
 - ll. Avoid usage of standalone air conditioning units
 - lll. BTU output of all equipment to be provided to electrical/mechanical engineers by Network Engineering
 - lV. Room must be maintained with positive air pressure
- n. Communications room doors are to be provided with locks and keyed to Maintenance and Operations Standards
 - l. Card access readers are accepted, and are to be covered by the project on costs

- o. Fire extinguishing water sprinklers may be provided in the ceiling of the communications room, but high temperature (100 C) fusible links shall be used and the system will be a dry pipe system
 - l. No wet piping systems are allowed in and/or through MDF/IDF spaces
- p. Smoke detectors and heat detectors shall be installed in the communications room and wired to the building fire alarm system
- q. Seal all penetrations in walls, floors, and ceilings with City of Calgary and UCIT Telecom Engineering Department approved fire stopping sealant installed in accordance with the manufacturer's tested methods. Unused conduits will be plugged and capped for fire stopping
- r. The communications room must have its own earth ground brought to the backboard
 - l. The earth ground bar is to be installed to the backboard (nearest rack).
 - ll. This ground must not be in common with building electrical grounds and shall join all communications riser grounds only at the building ground point
 - lll. The ground is used for sensitive equipment, not for bonding conduit and tray systems
 - lV. A minimum of #6 copper wire shall be used unless codes call for larger wire
 - V. The ground is to terminate on a solid copper ground busbar (50 mm x 260 mm x 5.6 mm bent to have a 20 mm standoff
- s. All communication racks to be grounded to the main grounding busbar individually
- t. Panduit four post racks with 8" cable managers are the approved rack by the University of Calgary IT Department – installation to be coordinated by U of C and sub-trades
- u. Bonding - In all cases where pairs enter or leave the cable sheath with PIC cabling, the cable shield must be bonded to the ground bus bar using #6 AWG copper wire

5.18.5 Communications Riser Rooms and Riser Systems

- 1. Design considerations for communications riser rooms and riser systems are the same as those noted above for main riser room
 - a. The room size is dictated by the number of cabinets required in the room and the unobstructed clearance required around the cabinets and back wall (see section 5.18.5 for typical room layout and sizing information)
 - l. Room size requirements shall be based on the square footage of the area being serviced so that future growth can be accommodated without substantial redesign
 - b. Five (5) 100 mm Electrical Metallic Tubing (EMT) conduit sleeves per riser room shall be provided for passage between floors
 - l. One sleeve will be used for fiber data cabling



- II. One sleeve will be used for copper Voice cabling
 - III. One sleeve will be used for copper Data cabling
 - IV. One sleeve will be used for DAS (Distributed Antenna Systems) cabling
 - V. The fifth sleeve will allow for quick and inexpensive growth and change
 - VI. These sleeves must be equipped with removable fire stops
 - VII. All sleeves must be bonded to the building ground system
 - VIII. All sleeves shall have conduit extending 5cm above the floor slab to prevent water damage in the event of a flood
- c. Provide Electrical Metallic Tubing (EMT) conduit and/or open plenum basket tray to support cable runs between the riser rooms on each floor – as well as horizontally from riser to edge communications outlets
- I. EMT to be designed to a 40% fill rate
 - II. Basket tray in to communications rooms are to also include water falling features to termination points
 - III. Tray and conduit sizing will depend on each approved manufacturers fill rates vs. cable diameter vs. transport medium



IV. Electrical Metallic Tubing (EMT) Conduit Fill Rate Chart:

Cable OD (inches)	Calc Cable Area Sq.inch	Conduit Trade Size	1/2 INCH	3/4 INCH	1 INCH	1 1/4 INCH	1 1/2 INCH	2 INCH	2 1/2 INCH	3 INCH	3 1/2 INCH	4 INCH
		Internal Dia.	0.622	0.824	1.049	1.38	1.61	2.067	2.731	3.356	3.834	4.334
		Calc area 31%	0.0942	0.16531	0.26792	0.46367	0.63111	1.04024	1.81591	2.74217	3.57895	4.57329
		Calc area 40%	0.12154	0.21331	0.3457	0.59828	0.81433	1.34224	2.34311	3.53829	4.618	5.90102
		Calc area 53%	0.16104	0.28263	0.45805	0.79273	1.07899	1.77847	3.10462	4.68823	6.1885	7.81886
		MAX NO. OF CABLES										
0.1	0.00785		15	27	44	76	103	171	298	450	588	751
0.105	0.00866		14	24	40	69	94	155	270	408	533	681
0.11	0.0095		12	22	36	63	85	141	246	372	486	621
0.115	0.01039		11	20	33	57	78	129	225	340	444	568
0.12	0.01131		10	19	30	53	72	118	207	313	408	521
0.125	0.01227		10	17	28	48	66	109	191	288	376	481
0.13	0.013 27		9	16	26	45	61	101	176	266	348	444
0.135	0.01431		8	15	24	41	57	93	163	247	322	412
0.14	0.01539		8	14	22	39	53	87	152	230	300	383
0.145	0.01651		7	13	21	36	49	81	142	214	279	357
0.15	0.0176 7		7	12	19	34	46	76	132	200	261	334
0.155	0.0188 7		6	11	18	31	43	71	124	187	244	312
0.16	0.02011		6	10	17	29	40	66	116	176	229	293
0.165	0.02138		5	10	16	28	38	62	109	165	216	276
0.17	0.0227		5	9	15	26	36	59	103	156	203	260
0.175	0.02405		5	9	14	25	34	56	97	147	192	245
0.18	0.02545		4	8	13	23	32	52	92	139	181	232
0.185	0.02688		4	8	13	22	30	50	87	131	171	219
0.19	0.02835		4	7	12	21	28	47	82	124	163	208
0.195	0.02986		4	7	11	20	27	45	78	118	154	197
0.2	0.03142		4	6	11	19	26	42	74	112	147	188
0.205	0.03301		3	6	10	18	24	40	71	107	140	178
0.21	0.03464		3	6	10	17	23	38	67	102	133	170
0.215	0.0363		3	6	9	16	22	37	64	97	127	162
0.22	0.03801		3	5	9	15	21	35	61	93	121	155
0.225	0.03976		3	5	8	15	20	33	59	89	116	148
0.23	0.04155		3	5	8	14	19	32	56	85	111	142
0.235	0.04337		3	5	8	13	18	31	54	81	106	136
0.24	0.04524		2	4	7	13	18	29	51	78	102	130
0.245	0.04714		2	4	7	12	17	28	49	75	98	125
0.25	0.04909		2	4	7	12	16	27	47	72	94	120
0.255	0.05107		2	4	6	11	16	26	46	69	90	115
0.26	0.05309			4	6	11	15	25	44	66	87	111
0.265	0.05515			4	6	11	14	24	42	64	83	107
0.27	0.0572 6			3	6	10	14	23	41	61	80	103
0.275	0.0594			3	6	10	13	22	39	59	77	99
0.28	0.06158			3	5	9	13	21	38	57	75	96
0.285	0.063 79			3	5	9	12	21	36	55	72	92
0.29	0.06605			3	5	9	12	20	35	53	70	89
0.295	0.06835			3	5	8	12	19	34	51	67	86
0.3	0.07069			3	5	8	11	19	33	50	65	83
0.305	0.07306			3	4	8	11	18	32	48	63	80
0.31	0.07548			3	4	8	10	17	31	47	61	78
0.315	0.07793			2	4	7	10	17	30	45	59	75
0.32	0.08042			2	4	7	10	16	29	44	57	73
0.325	0.08296			2	4	7	10	16	28	42	55	71
0.33	0.08553			2	4	7	9	15	27	41	54	69
0.335	0.08814			2	4	6	9	15	26	40	52	67
0.34	0.09079			2	4	6	9	14	26	39	51	65
0.345	0.09348				3	6	8	14	25	38	49	63
0.35	0.09621				3	6	8	14	24	36	48	61
0.355	0.09898				3	6	8	13	23	35	46	59
0.36	0.10179				3	6	8	13	23	34	45	58
0.365	0.10463				3	5	7	13	22	34	44	56
0.37	0.10752				3	5	7	12	21	33	43	55
0.375	0.11045				3	5	7	12	21	32	42	53
0.38	0.11341				3	5	7	12	20	31	40	52
0.385	0.11642				3	5	7	11	20	30	39	50
0.39	0.11946				3	5	7	11	19	29	38	49
0.395	0.12254				3	5	6	11	19	29	37	48
0.4	0.12566				2	4	6	10	18	28	36	47
0.405	0.12882				2	4	6	10	18	27	36	46
0.41	0.13203				2	4	6	10	17	27	35	44
0.415	0.13527				2	4	6	10	17	26	34	43
0.42	0.13854				2	4	6	9	17	25	33	42
0.425	0.14186				2	4	5	9	16	25	32	41
0.43	0.14522				2	4	5	9	16	24	32	40



- V. Open Plenum Basket Tray Fill Rates are defined by the tray manufacture being installed
- d. Riser cables must be kept separate from all other cables
- e. All plywood mounted with in the room shall be painted with fire retardant paint (electrical grey)
- f. All communication racks are to be grounded to the main grounding bar individually with 6 AWG insulated wiring
- g. The size of the communication riser room will vary depending on the floor space being covered. The following tables and diagrams indicate the required space requirements for various sized installations. It should be noted that typical requirements will be based on floor space and not initial space utilization due to the very high costs of adding additional capacity at a later date

Table = Rack Density vs. Base Room Sizing

Number of Racks/cabinets	Riser Room Size
1	2.5 m * 3 m
2	3 m * 3 m
3	3.5 m * 3.5 m

Diagram: One cabinet telecommunications room

One Rack	Top Plane 4 Post Rack Layout	Panduit R4P
----------	------------------------------	-------------

REFERENCE TABLE	
[1]	3000 mm (3.0m)
[2]	2500 mm (2.5m)
[3]	965 mm (0.965m)
[4]	1018 mm (1.018m)
[5]	1120 mm (1.12m)

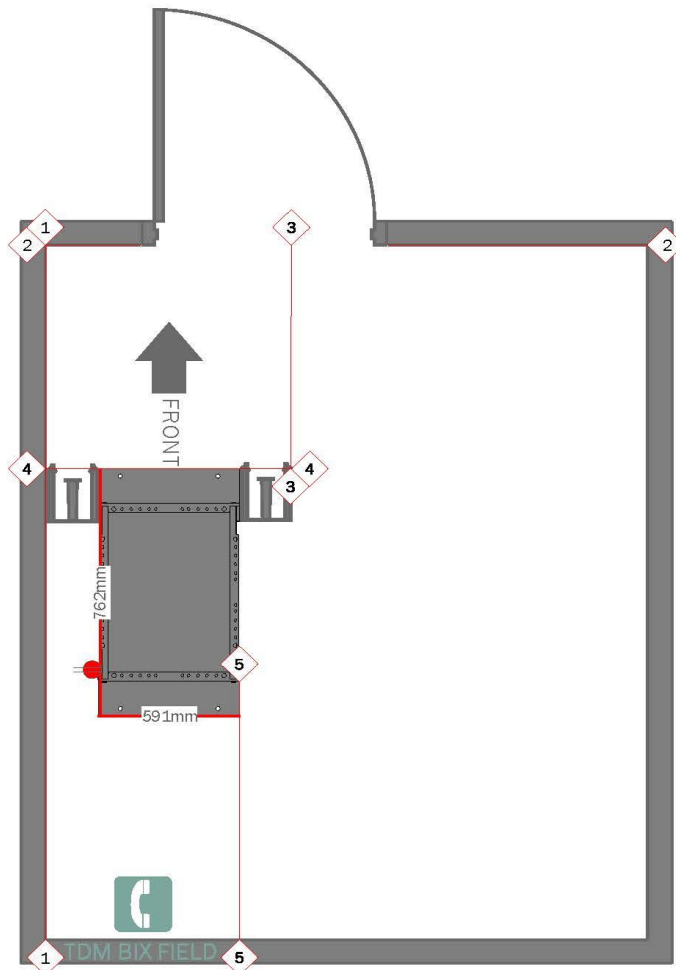

Diagram: Two cabinet telecommunications room

Two Racks	Top Plane 4 Post Rack Layout	Panduit R4P
-----------	------------------------------	-------------

REFERENCE TABLE	
[1]	3000 mm (3.0m)
[2]	3000 mm (3.0m)
[3]	1130 mm (1.130m)
[4]	1835 mm (1.835m)
[5]	940 mm (0.94m)

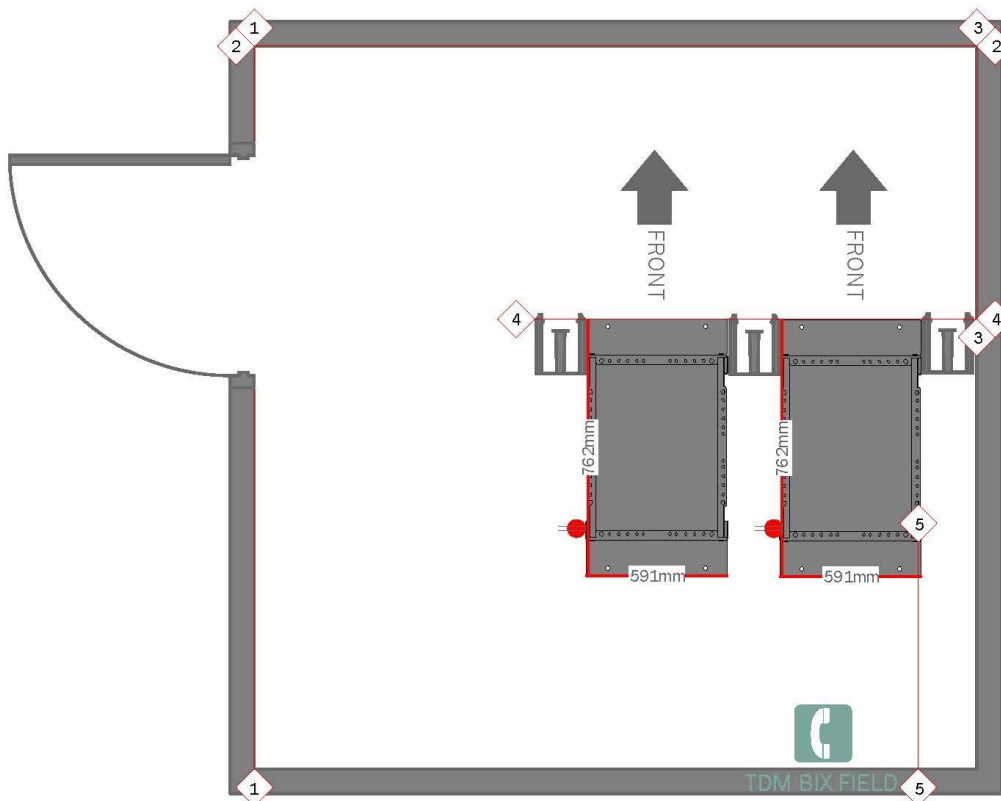
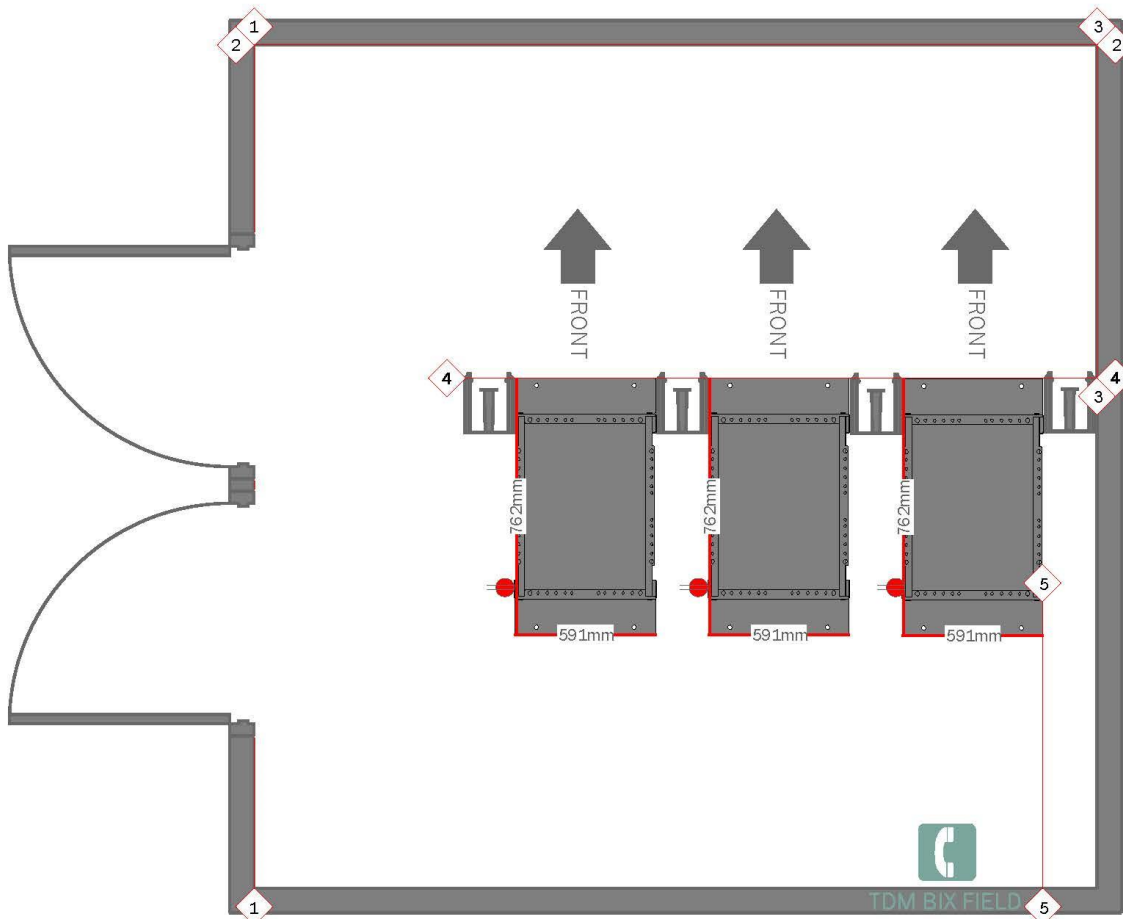

Diagram: Three cabinet telecommunications riser room

Three Racks	Top Plane 4 Post Rack Layout	Panduit R4P
-------------	------------------------------	-------------

REFERENCE TABLE	
[1]	3500 mm (3.5m)
[2]	3500 mm (3.5m)
[3]	1380 mm (1.38m)
[4]	2625 mm (2.625m)
[5]	1205 mm (1.205m)



5.18.6 Station Cable Distribution

1. Above Floor
 - a. Centralized conduit system
 - I. **Refer back to section 5.18.5 (1c.IV) for type and fill rate details**
 - b. Centralized tray system
 - I. **Refer back to section 5.18.5 (1c.V) for type and fill rate details**
2. Raised Floor
 - a. Centralized tray system
 - I. **Refer back to section 5.18.5 (1c.V) for type and fill rate details**
3. 2 copper cables per workstation location
 - a. If conduit is to be installed each outlet requires its own run of conduit (no daisy-chaining) either to the main cabling pathway, or directly back to the main Comm. Room
 - b. Outlets are to be mounted to same AFF (above floor finish) as electrical receptacles
4. 4 copper cables per AV meeting room TV mount location
5. Terminated on 2 U 48 port patch panels (unloaded)
 - a. To be supplied and installed by the Electrical Contractor (EC)
 - b. Refer to section '5.18.12: Parts and Components' for further detailed information
 - c. See 'Appendix A' for rack layout standard
6. Station cables to be terminated on patch panels in ascending order based on room numbers for the floor

5.18.7 Cable Labelling

1. Labelling for Copper and Fiber (Riser room and faceplate):
 - a. **All cable labels will follow destination tagging**
 - b. At the faceplate – the label will include:
 - I. Telecom Riser Room Number/ Rack # / Patch Panel Letter / Patch Panel Port Number
 - c. At the data rack, patch panel end, the label will include:
 - I. Room number / port number

2. New Installations:

a. Data racks:

- I. Numbered 1, 2, 3, etc. from left to right when viewed from the front of the racks

b. Patch Panels:

- I. Patch panels shall be labelled alphabetically
- II. Lettered A, B, C etc, from top to bottom
- III. See 'Appendix A' for rack layout standard

5.18.8 Testing Copper and Fiber Plants

1. See section 5.18.14: Appendix B (Copper and Fiber Testing)

5.18.9 Telephony Services

1. Projects & Major Renovations

1. All new projects and major renovations are required to be VoIP capable. Final decisions on the Telephony system to be installed will be made on a project by project basis.
2. Projects must carry the cost of all VoIP and Analog handsets, and the upgrade of any network hardware to support voice network traffic.
3. Analog Courtesy/Emergency phones shall be specified on a project by project basis depending on project floor space and user requirements.
4. Analog emergency phones shall be connected to the University of Calgary PBX and will be mounted in designated locations

2. Voice over Internet Protocol (VoIP)

1. All VoIP phone hardware will be supplied, installed, and maintained by the University of Calgary Voice Services Department with the exceptions of project installs (with the exception of projects, noted in 5.18.9.1.b).
2. All MDF room headend network equipment will require dual power supplies, with one being connected to standard utility power and one being connected to an Uninterruptible Power Supply (UPS)

3. Analog & Digital Phones

1. All Analog and Centrex Digital Telephone hardware will be supplied, installed, and maintained by the University of Calgary Voice Services Department

4. Fax lines

1. Analog fax circuits will be connected back to the University of Calgary's PBX and will be installed and maintained by the University of Calgary Voice Services Department
2. VoIP fax services will be supplied, installed, and maintained by the University of Calgary via the use of Analog Telephone Adapters (ATA)

5. Conference Phone

1. Analog Conference phone circuits will be connected back to the University of Calgary's PBX and will be installed and maintained by the University of Calgary Voice Services Department
2. VoIP Conference phone connectivity will be supplied by the University of Calgary Network Services Department
3. Both Analog and VoIP Conference phone hardware will be supplied by either the end users Department/Faculty or Project group

6. Classroom Wall Mounted Phones

1. Classrooms fitted with a fixed Commedia podium will have the phone mounted to the closest wall adjacent to the podium. Classrooms without a fixed Commedia podium will have the phone mounted in the front of the room adjacent to the black/whiteboards, on the side nearest the door.
2. Classroom wall phone locations will utilize Electrical Metallic Tubing (EMT) with an 1104 style electrical box and will be secured to structure. The use of Flexible Metal Conduit (FMC), Liquid Tight Flexible Metal Conduit (LFMC), and drywall mounted communications bracket hardware such as "Caddy Clips" will not be accepted.
3. The standard mounting height for Classroom phones shall be +1370mm (54") AFF to the center of the outlet.
4. There shall be at least 200mm (8") clearance on each side from the vertical center, at least 600mm (24") from a chalkboard, and at least 600mm (24") clearance from the horizontal center above and below.
5. Classroom wall phone locations will require a single cable, either Cat6 or Cat6A that is to match the existing structured cabling system or the new structured cabling system. Outlet labeling will follow Section 5.18.7.2 - Labelling for Copper and Fiber.
6. Install a single gang wall plate, with protruding wall-mounting studs. (Such as the Belden AX102902)

7. Standard Wall Mounted Phones

1. Standard wall phone locations will utilize Electrical Metallic Tubing (EMT) with an 1104 style electrical box and will be secured to structure. The use of Flexible Metal Conduit (FMC), Liquid Tight Flexible Metal Conduit (LFMC), and drywall mounted communications bracket hardware such as "Caddy Clips" will not be accepted.
2. Standard mounting height for the classroom phones shall be +1370mm (54") AFF to the center of the outlet.
3. There shall be at least 200mm (8") clearance on each side from the vertical center, and at least 600mm (24") clearance from the horizontal center above and below.
4. Standard wall phone locations will require a single cable, either Cat6 or Cat6A that is to match the existing structured cabling system or the new structured cabling system. Outlet labeling will follow Section 5.18.7.2 - Labelling for Copper and Fiber.
5. Install a single gang wall plate, with protruding wall-mounting studs. (Such as the Belden AX102902)

8. Push Button Help/Emergency phones – Indoor locations

1. Supply and install Guardian HDE-11 (flush-mounted)
2. The Standard mounting height for the Emergency Phone shall be +1170mm (46") AFF to the center of the mounting box (8.3"x10"x2.45"). (This refers to the Guardian HDE-11 units with the stainless fronts). Note that only the original manufacturer's back boxes are to be used. A

cut out of 8.75"x10" is required for this box and it must be mounted in the center of the hole.

3. Signage/Blue light shall be mounted as high as practical but need not exceed + 3m (10') to the bottom of the light.
4. Push Button Help/Emergency locations will require a single cable, either Cat6 or Cat6A that is to match the existing structured cabling system or the new structured cabling system. Outlet labeling will follow Section 5.18.7.2 - Labelling for Copper and Fiber.

9. Push Button Help/Emergency phones – Outdoor locations (required at all building main entrances)

1. Install a yellow weatherproof surface mount emergency phone Guardian HDE-12. All conduit entries for outdoor help phones and blue lights shall be into the bottom of back boxes. Deviations from the specified installation will be deemed - special assembly and will be subject to approval.
2. The Standard mounting height for the Emergency Phones shall be +1170mm (46") AFF to the center of the mounting box (8.3"x10"x2.45"). Note - only original manufacturer's back boxes are to be used.
3. Signage/Blue light shall be mounted as high as practical but need not exceed + 3m (10') to the bottom of the light.
4. Push Button Help/Emergency locations will require a single cable, either Cat6 or Cat6A that is to match the existing structured cabling system or the new structured cabling system. Outlet labeling will follow Section 5.18.7.2 - Labelling for Copper and Fiber.

10. Elevator Help Phones

1. Provide dedicated cables matching the installed structured cabling system, for each elevator car, and or a single cable in the case of a Smart Elevator Call System, one for elevator maintenance (to be located in the Elevator machine room), and one for the Fire Marshall phone (to be located in the main floor lobby).
2. The University of Calgary Voice Services Department will supply one Analog phone line per elevator car, or a single Analog phone line when a Smart Elevator call system is utilized.

5.18.10 Network Services Equipment

1. Every project deployment will use the University of Calgary's current standards for network equipment and device configuration
2. Project budgets carry the burden for the services they will use. This will ensure proper system operation and quality support
3. Budgetary figures for the required equipment will be provided by the University of Calgary IT Facilities Intake Team during the project cycle
 - a. This equipment is documented in the document "Data Network Standards: In Buildings"
4. Based on budgetary figures provided to the project the University of Calgary IT Facilities Intake Team will purchase, deploy, and configure all active components that are specifically required for voice and data services

5.18.11 Other UCIT Services

1. All server requirements should be housed in a UCIT data center. This will reduce the significant overhead costs associated with small data center construction and operation and reduce the environmental footprint of these systems. Due to the scale and level of support available through UCIT, system reliability is usually higher in this scenario as well. UCIT can and will provide further information as required
2. Panduit cabinets and parts are the standardized network racks and modular solution for the data centers

5.18.12 Parts and Components

1. The University of Calgary Information Technologies department uses a standard list of parts and components to decrease deployment time and improve long term serviceability of the systems. Occasional specialized applications may require components that are not listed below but in any case UCIT will approve the components that are to be used on specific projects

BELDEN CAT6a	PT#/SKU	Color
10GXS Category 6A Enhanced Cable, 4 Pair, U/UTP, CMP	10GXS13009A1000	WHITE
48 Port 2U Flex Patch Panel (MDVO)	AX101458	BLACK
10GX Modular Jacks - KeyConnect	AX102282	WHITE
KeyConnect Deco Adapter - 2 Port	AX106573-EW	WHITE
KeyConnect Deco Adapter - 3 Port	AX106574-EW	WHITE
KeyConnect Deco Adapter - 4 Port	AX106575-EW	WHITE
10GX Modular Jacks - MDVO	AX102271	WHITE
MDVO Single-Gang Faceplates - 2 Port	AX101433	WHITE
MDVO Single-Gang Faceplates - 4 Port	AX101437	WHITE
CAT 6A Small Diameter Patch Cords - 7 foot	CAD1109007	WHITE
CAT 6A Small Diameter Patch Cords - 10 foot	CAD1109010	WHITE

BELDEN CAT6	PT#/SKU	Color
Premium Performance System Cable (3600)	3613 004A1000	YELLOW
48 Port 2U Flex Patch Panel (MDVO)	AX101458	BLACK
CAT6 Modular Jacks - MDVO	AX101071	BLUE
MDVO Single-Gang Faceplates - 2 Port	AX101433	WHITE
MDVO Single-Gang Faceplates - 4 Port	AX101437	WHITE
MDVO 106 Housing - 4 Port	AX100309	Almond
CAT 6 Small Diameter Patch Cords - 7 Foot	C6D1104007	YELLOW
CAT 6 Small Diameter Patch Cords - 10 Foot	C6D1104010	YELLOW

COMMSCOPE CAT6a	PT#/SKU	Color
GigaSPEED X10D® 2091B ETL Verified Category 6A U/UTP Cable	2091B WHT	WHITE
Discrete Distribution Module Panel, M-series, UTP, 2U, 48 port	CPP-UDDM-M-2U-48	BLACK
GigaSPEED X10D® MGS600 Series Information Outlet RJ45 Jack	MGS600-262	WHITE
L Type Flush Mounted Faceplate, 2 port	M12L-262	WHITE
L Type Flush Mounted Faceplate, 4 port	M14L-262	WHITE
M14CE Type Furniture Faceplate, 4 port	M14CE-262	WHITE
MiNo6A Series Category 6A U/UTP Reduced Diameter Patch Cord - 7 Foot	CO199K2-08F007	WHITE
MiNo6A Series Category 6A U/UTP Reduced Diameter Patch Cord - 10 Foot	CO199K2-08F010	WHITE

PANDUIT CAT6a	PT#/SKU	Color
Advanced MaTriX Category 6A UTP SD Cable	PUP6ASD04-WH	WHITE
Mini Com 48-port modular flush mount 48 port 2U patch panel	CPP48FMWBLY	BLACK
Category 6A, RJ45, 10 Gb/s, 8-position, 8-wire universal module	CJ6X88TGAW	WHITE
Mini Com Classic series single gang vertical faceplate - 2 Port	CFPL2WHY	WHITE
Mini Com Classic series single gang vertical faceplate - 4 Port	CFPL4WHY	WHITE
Category 6A Performance, 28AWG, UTP Patch Cord, CM/LSZH, Off White, 7ft.	UTP28X7	WHITE
Category 6A Performance, 28AWG, UTP Patch Cord, CM/LSZH, Off White, 10ft.	UTP28X10	WHITE

EDGE RACK SOLUTION	PT#/SKU	Color
Four Post 45 RU, 30in deep, #12-24 Threaded Mounting Hole Rack	R4P	BLACK
Single Sided Vertical Cable Manager, 8 inch	PR2VFD08	BLACK
SMALL EXISTING ROOMS: Middle Atlantic SFR Series Rack, 24" D X 27 1/4" H	SFR-12-24	BLACK
PON SYSTEM(S): Two Post 45 RU, #12-24 Threaded Mounting Hole Rack	R2P	BLACK

FIBER OPTICs (Inside and Outside Plants)	PT#/SKU	Color
<i>Updated list coming soon, early 2021</i>		

5.18.13

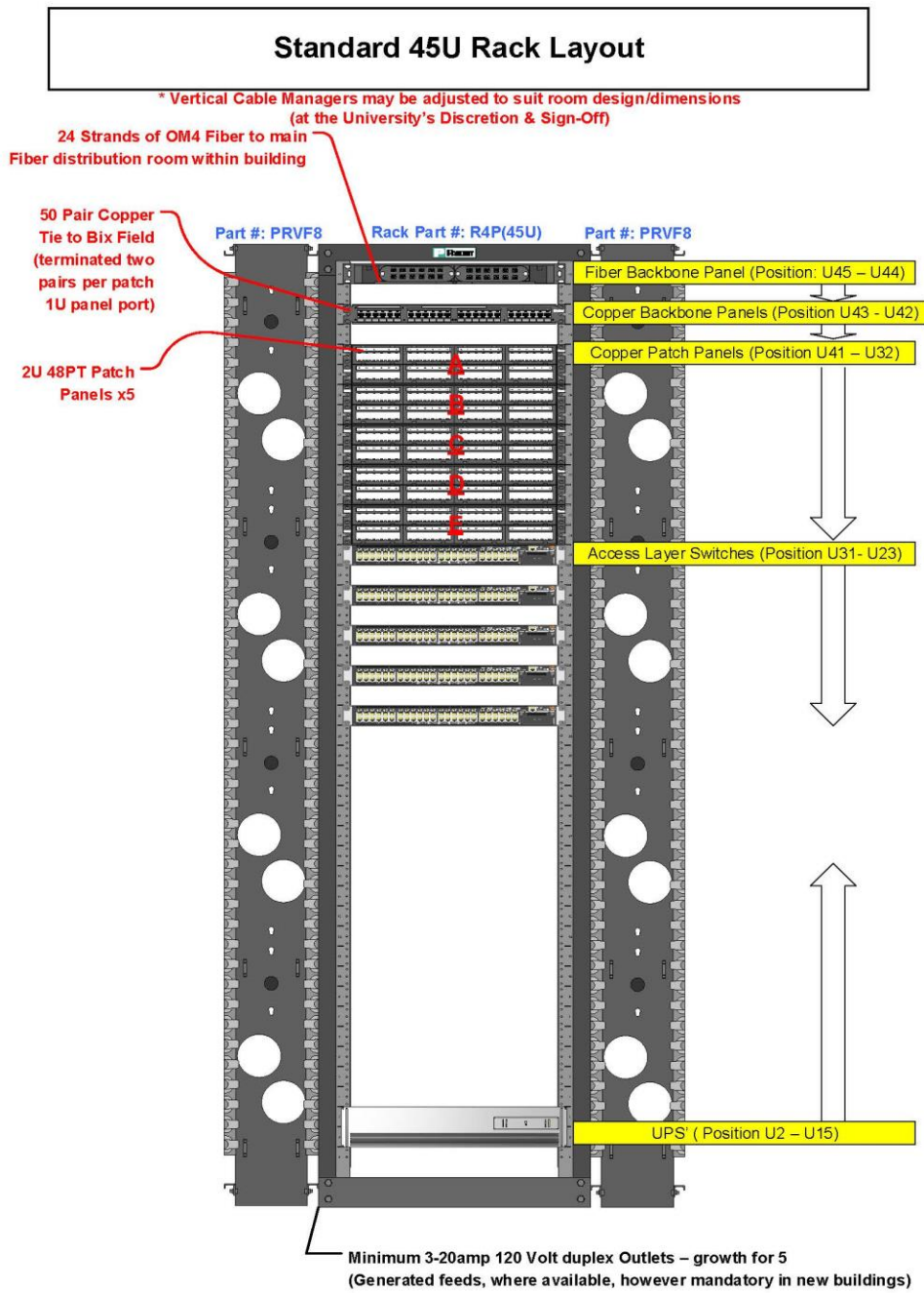

Shown: 240 Structured cables w/5-48 port switch stack

Standard 45U Rack Layout (Top View)

* Vertical Cable Managers may be adjusted to suit room design/dimensions
(at the University's Discretion & Sign-Off)

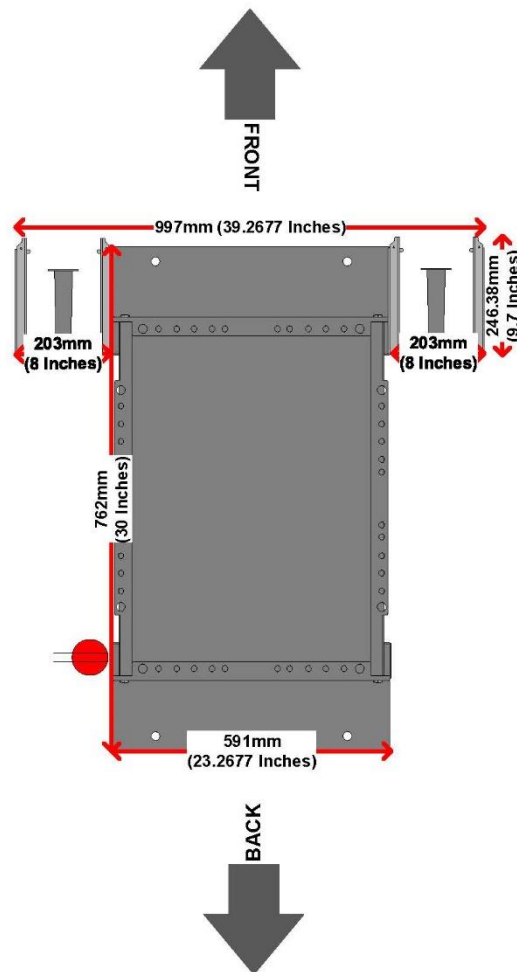

Shown: Four post Panduit R4P rack w/power

Standard 45U Rack Layout (Side View)

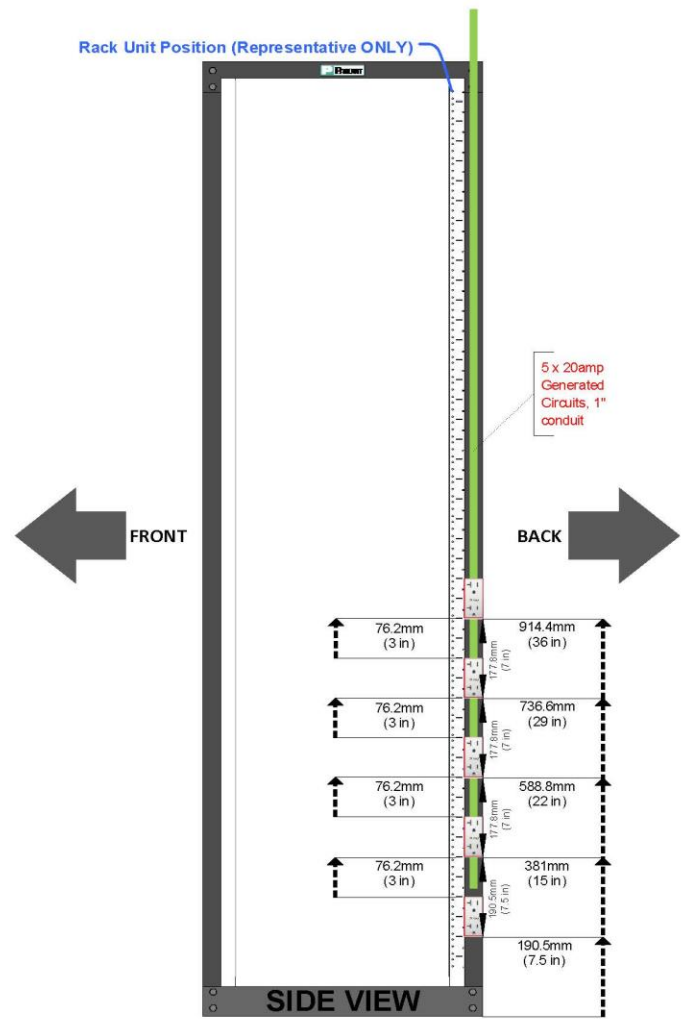

Shown: Mounting heights of electrical circuits

5.18.14 Appendix B (Copper and Fiber Testing)

1. Copper cable plant:
 - a. Backbone and riser cable: Perform the following tests on the backbone and riser cables:
 - I. Continuity and polarity test for each pair
 - II. dB loss of white blue pair of each binder group
 - III. Length of white blue pair of each binder group
 - IV. Test results in the form of a soft copy to be emailed Network Services Department
2. Copper Structured Cabling:
 - a. Each drop shall be permanent link tested to meet the transmission performance specifications for the category of cabling system being installed

- I. Permanent Link Testing Definitions

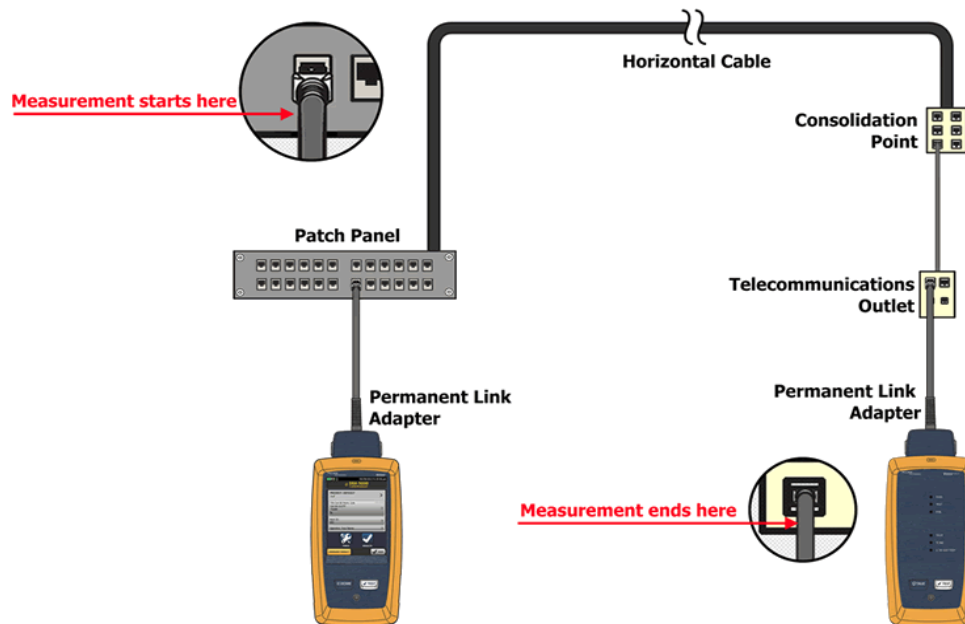
Three connector permanent link definition:

[Following test applies to BIX systems - as well as patch panel based ones]

Two connector permanent link definition:

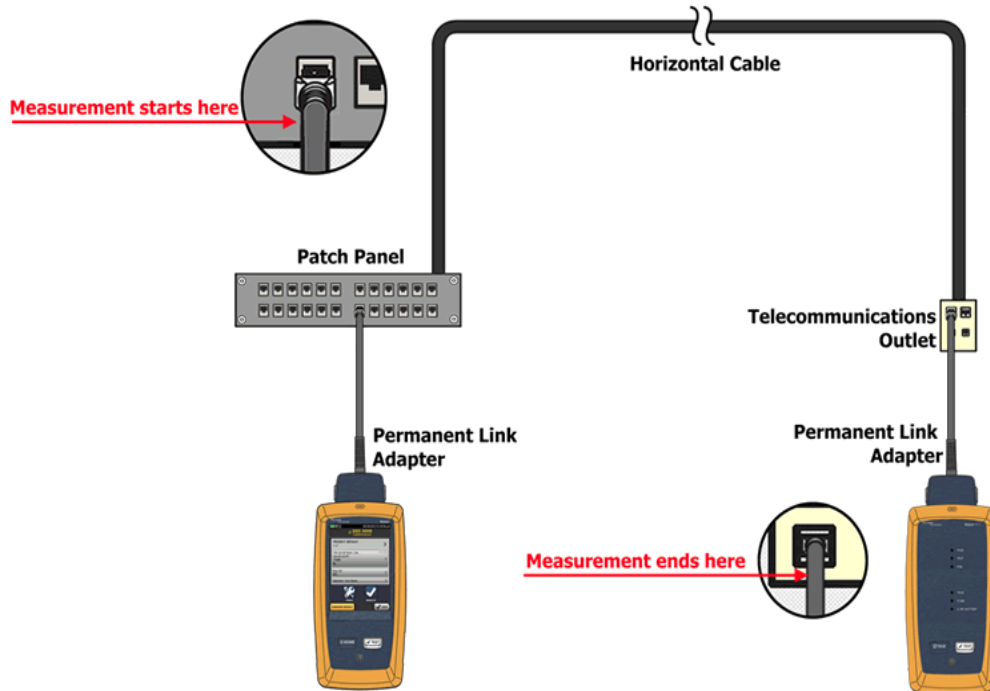

Data center two connector permanent link definition:

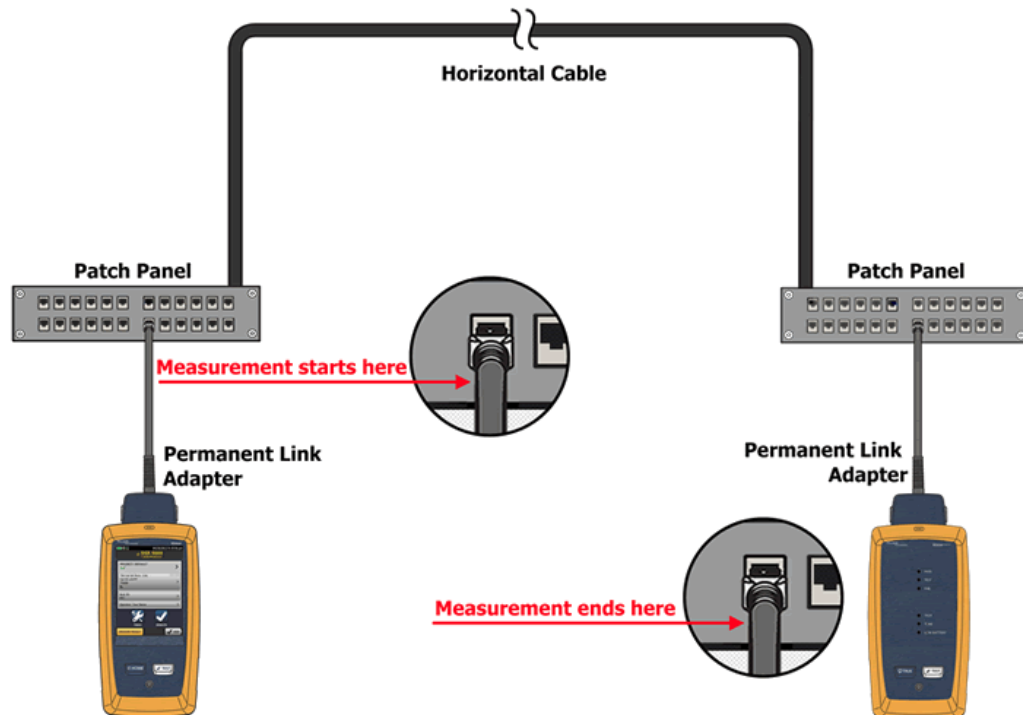

II. Modular Plug Terminated Link (MPTL)
[specific to 'Passive Optical Networks' Copper to work stations]

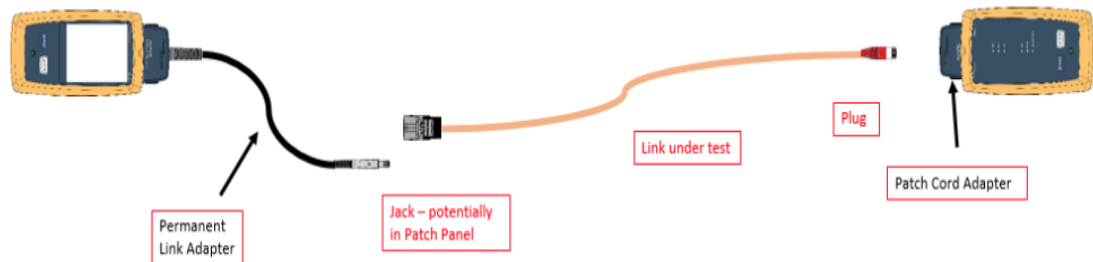

- III. Test results in the form of a soft copy to be emailed to the University of Calgary IT Facilities Intake Team
- IV. While performing certification tests the manufacturer's cable type must be entered into the tester to maintain accurate lengths and loss results. Failure to enter this information prior to testing will result in the contractor having to re-certify the entire cable plant
- V. Cable testers have to be up to date on the manufactures specifications regarding calibrations
Out of date test tool results will not be accepted
- VI. The University of Calgary IT Department reserves the right to withhold Data and/or Voice service installations, if the above testing requirements are not met

3. Fiber Optic(s):

- a. The contractor or manufacturer shall test each fiber for attenuation at 1300 nm for Multi-Mode fiber and 1550 nm for Single-Mode fiber using an Optical Time domain Reflectometer (O.T.D.R.)
 - I. Testing should be completed while fiber is still on reel
 - II. The University of Calgary IT Department reserves the right to withhold Data and/or Voice service installations, if the above testing requirements are not met
- b. Contractors shall provide the results of bandwidth and attenuation tests performed at the place of manufacture to The University of Calgary Network Engineering.
 - I. These results MUST be on the original form provided by the manufacturer
- c. O.T.D.R. tests are to be conducted upon completion of a fiber installation and are to be conducted from both directions

- I. No tests are required for non-terminated fibers
- d. The University of Calgary Network Engineering reserves the right to inspect and test cables at any time to ensure proper installation and testing procedures
- e. No fiber optic cable installation will be accepted without the following tests being performed:
 - I. Multimode: For every multimode fiber installed end-to-end attenuation loss testing shall be performed at both 850 nm and 1300 nm wavelengths bi-directionally using Method B single jumper reference in accordance to the ANSI/TIA 568 C and ANSIA TIA 527 standards. The use of a mandrel is required for multimode testing
 - i. OTDR tests need to be taken for both directions at both wavelengths
 - ii. O.T.D.R. graphs are to be submitted to Network Services
 - II. Single Mode: For every single-mode fiber installed end-to-end attenuation loss testing shall be performed at both 1310 and 1550 nm wavelengths bi-directionally using Method B single jumper reference in accordance to the ANSI/TIA 568 C and ANSIA TIA 527 standards
 - iii. OTDR tests need to be taken for both directions at both wavelengths
 - iv. O.T.D.R. graphs are to be submitted to Network Services
- f. Test labels: Building and Room # - FDF XX/Position – Building and Room # - FDF XX/Position – Strand #
 - I. Building number end A
 - II. FDF Letter/Position for building end A
 - III. Building number end B
 - IV. FDF Letter/Position for building end B
 - V. Strand number
 - VI. (MS 016 – FDF 1A/C02 – AD 010 – FDF 1B/E02 – Strand 03) for example
- g. While performing certification tests and OTDR tests the manufacturer's cable type must be entered into the tester to maintain accurate lengths and loss results. Failure to enter this information prior to testing will result in the contractor having to re-certify the entire cable plant
- h. Optical link loss testing:
 - I. Multimode and Single mode links
 - i. The link attenuation shall be calculated by the following formulas
 - $\text{Link Attenuation (dB)} = \text{Cable_Attn (dB)} + \text{Connector_Attn (dB)} + \text{Splice_Attn (dB)}$
 - $\text{Cable_Attn (dB)} = \text{Attenuation_Coefficient (dB/km)} * \text{Length (Km)}$
 - $\text{Connector_Attn (dB)} = \text{number_of_connector_pairs} * \text{connector_loss (dB)}$

(iv) Maximum allowable connector_loss = 0.30 dB

(v) Splice_Attn (dB) = number_of_splices * splice_loss (dB)

(vi) Maximum allowable splice_loss = 0.03 dB

(vii) The values for the Attenuation_Coefficient (dB/km) are listed in the table below:

Type of Optical Fiber	Wavelength (nm)	Attenuation coefficient (dB/km)	Wavelength (nm)	Attenuation coefficient (dB/km)
Multimode 62.5/125 μm	850	3.0	1300	.70
Multimode 50/125 μm	850	2.5	1300	.80
Single-mode (Inside plant)	1310	0.35	1550	0.22
Single-mode (Outside plant)	1310	0.35	1550	0.22

- I. OTDR testing
 - i. Reflective events (connections) shall not exceed 0.5 dB
 - ii. Non-reflective events (splices) shall not exceed 0.03 dB
- II. Magnified end face inspection
 - i. Fiber connections shall be visually inspected for end face quality.
 - ii. Scratched, pitted or dirty connectors shall be diagnosed and corrected
- b. The cable attenuation shown by the OTDR shall be checked against the manufacturer's stated maximum attenuation
 - I. A minimum 200 foot fiber test lead shall be used between the OTDR and the fiber under test
 - II. A minimum 200 foot fiber test lead shall be connected to the far end of the fiber under test with the OTDR
 - III. The test procedures must comply with ANSI/TIA 568 C and ANSIA/TIA 527 standards. Along with The University of Calgary Network Engineering limits listed in this standard
 - IV. The cable shall meet or exceed the requirements of the specifications for fiber dimensions, attenuation, band width, numerical aperture, fire proof test, cable bending, tensile load, impact resistance, crush resistance, and attenuation versus temperature

5.18.15 Appendix C (Installation Standards for Fiber Duct)

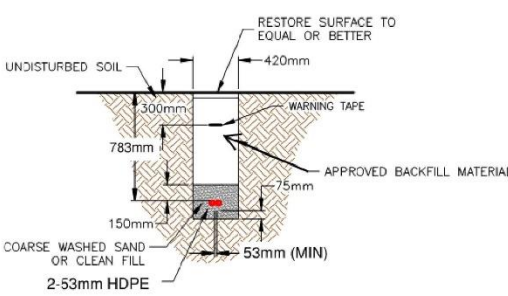

**2 - 53mm HDPE CONDUITS
TRENCHING OPTION A**
Scale: N.T.S.

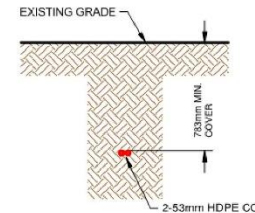

**2 - 53mm HDPE CONDUITS
BORING OPTION B**
Scale: N.T.S.



3 DURA-LINE PUSH-LOCK
Scale: N.T.S.



4 DURA-LINE SPLIT-LOCK II
Scale: N.T.S.

GENERAL NOTE:

- TRENCHING OPTION A OR BORING OPTION B SUBJECT TO SITE INVESTIGATION ON WHICH OPTION IS APPLICABLE.
- CONTRACTORS CHOOSE TO TRENCH INSTEAD OF HORIZONTAL DRILLING THROUGH SHALL NOT CUT DOWN OR DISTURB TREES AND NEED TO RESTORE THE EXISTING GROUND TO NORMAL CONDITION WHICH INCLUDED TRAFFIC ROAD I.E..

GENERAL NOTE:

- OPTIONS FOR INSTALLATION OF DURA-LINE PUSH-LOCK AND SPLIT-LOCK COUPLERS. CONFIRM ON SITE PRIOR TO INSTALLATION.



UNIVERSITY OF CALGARY
FACILITIES DEVELOPMENT

This is a copyright drawing and shall not be re-used, sold or re-produced without written permission and must be returned at completion of work to: upon request.
The contractor shall check and verify all dimensions and report all errors and omissions to the architect prior to construction.
This drawing must not be scaled.
This drawing shall not be used for construction purposes until so approved.

1	Issued for Design Standards	2019.11.27
REV.	DATE	DATE
PROJECT TITLE: FIBRE OPTIC CABLE INSTALLATION		
DRAWING TITLE: DETAILS #1		
PROJECT NO: BAS#190160	TRUE NORTH	
SCALE: AS NOTED		
CLIENT: HD		
CHECKED: JW	SHEET NO: E1	
DRAWN DATE: 2019.11.27		

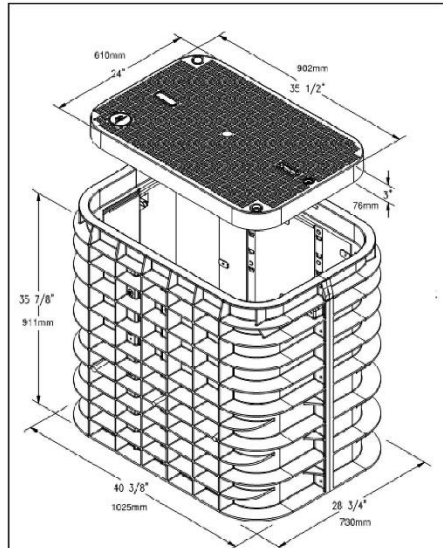

CHANNEL 24x36x36 ENCLOSURE DETAIL
N.T.S.

1 MANHOLE
Scale: N.T.S.

NOTE:

INSTALLATION STANDARD D&M CONCRETE PRODUCTS LTD.
UNIVERSAL PULL BOX BIP.E3500.SL3 OR EQUAL.

HDPE PLACEMENT IN SYNERTECH PULL BOXES

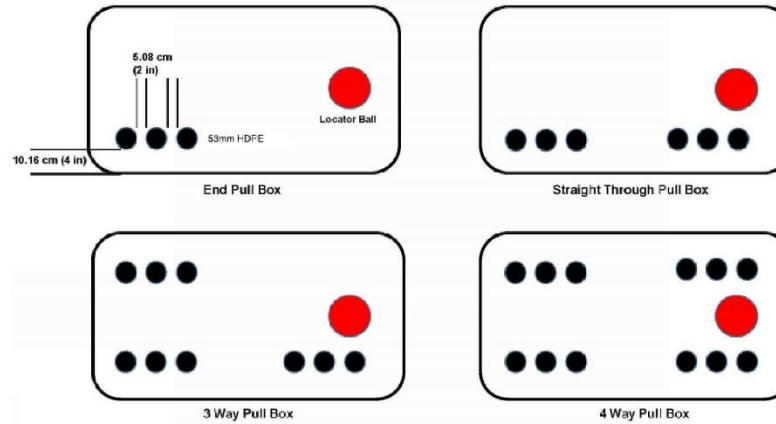

HDPE PLACEMENT IN SYNERTECH PULL BOX CONSTRUCTION NOTES

1. 53mm HDPE'S ARE TO PLACE 5.08cm (2") APART AND 10.16cm (4") FROM THE WALL.
2. A MINIMUM OF 305mm OF 25mm WASHED GRAVEL, DEPENDING ON SOIL CONDITIONS, IS TO BE PLACED UNDER PULL BOX AND EXTEND 300mm BEYOND SIDES.
3. THE HDPE IS TO BE CUT 15.24cm (6") ABOVE THE GRAVEL.
4. END OF ALL CONDUITS ARE TO BE CAPPED AT ALL LOCATIONS.



UNIVERSITY OF CALGARY

FACILITIES DEVELOPMENT

This is a copyright drawing and shall not be reprinted, copied or revised without written permission and must be returned at completion of work, upon request.

The contractor shall check and verify all dimensions and report all errors and omissions to the architect prior to construction.

This drawing must not be scaled.

This drawing shall not be used for construction purposes until so approved.

1	Issued for Design Standards	2019.11.27
no.	drawn by:	date
	revision:	(DDMMYY)

project title
**FIBRE OPTIC CABLE
INSTALLATION**

drawing title
DETAILS #2

project no.
BAS#190160

scale
AS NOTED

drawn
HD

checked
JW

sheet date
2019.11.27

sheet no.
E2

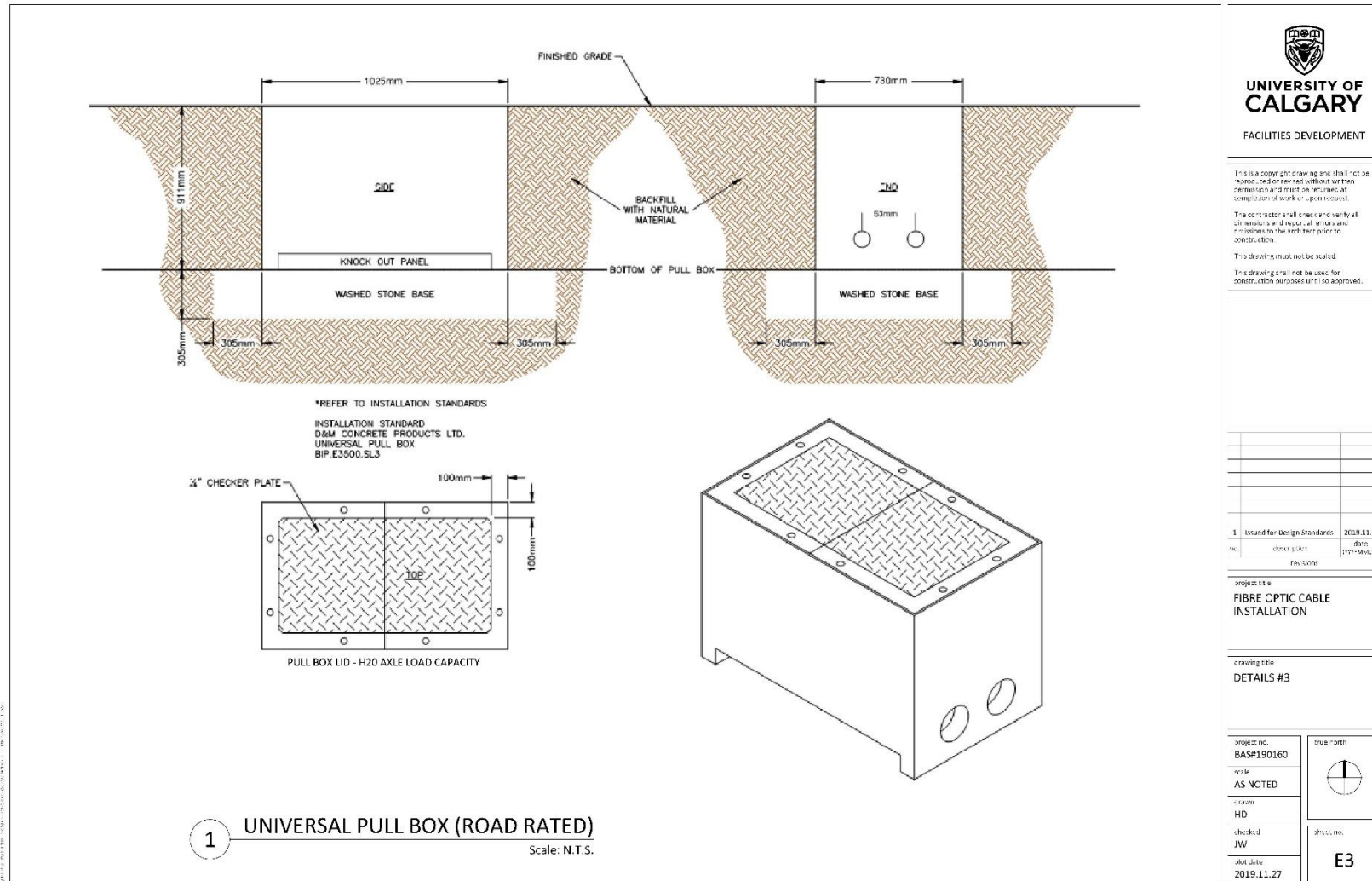

**UNIVERSITY OF
CALGARY**

FACILITIES DEVELOPMENT

This is a copyright drawing and shall not be reproduced or derived without written permission and must be returned at completion of work, upon request.

The contractor shall check and verify all dimensions and report all errors and omissions to the architect prior to construction.

This drawing must not be scaled.

This drawing shall not be used for construction purposes until so approved.

NO.	DESCRIPTION	DATE
1	Issued for Design Standards	2019.11.27
	DESIGNED BY	DATE
	REVISED BY	DATE

PROJECT TITLE
**FIBRE OPTIC CABLE
INSTALLATION**

DRAWING TITLE
DETAILS #3

PROJECT NO.
BAS#190160

SCALE
AS NOTED

DESIGNED BY
HD

CHECKED BY
JW

ISSUE DATE
2019.11.27

SHEET NO.
E3

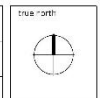

**UNIVERSITY OF CALGARY INFORMATION TECHNOLOGY
MINIMUM INSTALLATION STANDARDS FOR FIBER OPTIC PULL BOXES AND CONDUIT.**

PRE CONSTRUCTION MEETING

CONTRACTOR IS TO CONTACT INFORMATION TECHNOLOGY PRIOR TO CONSTRUCTION:
 - TO INTRODUCE CONTRACTOR AND IT PERSONAL.
 - TO REVIEW CONTRACTOR QUALIFICATIONS.
 - TO CONDUCT AN OVERVIEW AND DISCUSS STANDARDS OF INSTALLATION.
 - DISCUSS ANY PROBLEMS OR CONCERNS CONTRACTOR MAY HAVE.

CONTACT: JASON WRIGHT INFORMATION TECHNOLOGY AT 403 210 9301

PROJECT MANAGEMENT OFFICE WILL ISSUE CONSTRUCTION STANDARDS, DRAWING AND APPROVED UNIVERSITY OF CALGARY LINE ASSIGNMENT.

CONTRACTOR IS TO HAVE COPY OF DRAWINGS, INSTRUCTIONS, EXCAVATION PERMIT AND OTHER PERMITS ISSUED PRIOR TO THIS MEETING.

CONTRACTOR RESPONSIBILITIES

- TO ARRANGE FLAGGING AND LANE CLOSURES IS REQUIRED.
- HAVE ALL NECESSARY PERMITS ON SITE.
- TO HAVE ALL UTILITIES LOCATED AND EXPOSED IS REQUIRED.
- TO SUPPLY ALL PERSONAL AND EQUIPMENT IS REQUIRED FOR THIS PROJECT.
- TO SUPPLY ALL CONSTRUCTION MATERIAL REQUIRED UNLESS OTHERWISE SPECIFIED.
- REMOVE ALL EXCESS EXCAVATION MATERIAL FROM SITE UNLESS OTHERWISE APPROVED BY THE GENERAL CONTRACTOR.
- TO LANDSCAPE AREA OF CONSTRUCTION TO ORIGINAL OR BETTER CONDITION UPON COMPETITION UNLESS OTHERWISE INSTRUCTED BY THE GENERAL CONTRACTOR.
- ATTEND SCHEDULED GENERAL CONTRACTOR SITE MEETINGS IS REQUIRED.
- TO OBTAIN AND PAY FOR ALL APPLICABLE PERMITS AND LICENSES. DISPLAY ALL PERMITS IN A PROMINENT LOCATION.

CONDUIT INSTALLATION BY OPEN EXCAVATION

CONDUIT IS TO BE 2-53mm HDPE UNLESS AN ALTERNATIVE IS OTHERWISE AGREED UPON I.E. 1-102MM DB2 MAY BE USED IN SPECIFIC APPLICATIONS, I.E. EXISTING STUB OUT CONNECTIONS OR LATERALS TO PLANNED 102MM CONNECTIONS.

- IF ONE (1) 53mm HDPE IS REQUIRED THE PRIMARY COLOR IS ORANGE.
- IF TWO (2) 53mm HDPE ARE REQUIRED THE PRIMARY COLORS ARE ORANGE AND BLUE.
- UNDER NO CIRCUMSTANCES IS ANY ONE COLOR TO BE DUPLICATED UNLESS SPECIFIED OR APPROVED.
- PLACEMENT AND TYPES WILL BE INDICATED ON DRAWINGS.
- STANDARD CLEARANCES TO ALL UNDERGROUND AND SURFACE UTILITIES ARE TO BE MAINTAINED.
- ALL FACILITY CROSSING ARE TO BE DONE AT 90 DEGREES.
- CONDUIT IS TO BE LAID IN AS STRAIGHT A LINE AS POSSIBLE TO FACILITATE INSTALLATION OF CABLE.
- ALL STANDARDIZED HDPE CONDUIT COUPLER LOCATIONS ARE TO BE IDENTIFIED ON THE AS-BUILT DRAWINGS.
- A MAXIMUM OF THREE 90 DEGREE BENDS BETWEEN EACH ACCESS POINT (EXCEPT FOR 32mm/53mm HDPE SDR 11) WILL BE ALLOWED.
- CONDUITS ARE NOT TO ENTER CONCRETE PULL BOXES FROM BELOW UNLESS SPECIFIED OR EXTENUATING CIRCUMSTANCE DICTATE NECESSITY (MUST BE PRE-APPROVED).
- FOR OPEN EXCAVATION CONDUIT IS TO BE ENVELOPED BY AT LEAST 100mm OF SAND OR CLEAN FILL PRIOR TO BACK FILLING AND COMPACTION.

- TW90#14 WHITE COPPER TRACER WIRE IS TO BE INSTALLED IN PARALLEL TO CONDUIT WITH A MINIMUM OF 3.0m COILED. FEED THROUGH HOLE IN THE RECESSED LIFTING DIVOT OF THE PULL BOX LID.
- PULL ROPE OR MULE TAPE WITH A MINIMUM BREAKING STRENGTH OF 1200 POUNDS IS TO BE INSTALLED IN ALL CONDUIT, OTHER THAN HDPE CONDUIT, WITH A MINIMUM OF 1.0m COILED IN CONDUIT AT EACH END. HDPE MUST HAVE A PULL STRING INSTALLED TO PROVIDE CONTINUITY.
- END OF ALL CONDUITS ARE TO BE CAPPED AT ALL LOCATIONS.
- ALL CONDUITS ARE TO BE IDENTIFIED AS TO DIRECTION AND ALLOCATION (IF SPECIFIED). IF MORE THAN ONE CONDUIT IS INSTALLED IDENTIFICATION MUST MATCH AT EACH END IF CONDUIT IS NOT COLOR CODED.
- ALL CONDUIT THAT IS STUBBED OUT WILL HAVE A LOCATOR BALL PLACED AT THE STUB OUT LOCATION AND IDENTIFIED ON THE AS-BUILT.

CONDUIT INSTALLATION BY PLOWING

CONDUIT IS TO BE 53mm HDPE UNLESS OTHERWISE SPECIFIED ON CONSTRUCTION DRAWINGS:

- PLACEMENT WILL BE INDICATED ON DRAWINGS.
- MINIMUM INSTALLATION DEPTH IS TO BE 1.0m UNLESS OTHERWISE SPECIFIED.
- TW90#14 WHITE COPPER TRACER WIRE IS TO BE INSTALLED PARALLEL TO CONDUIT WITH A MINIMUM OF 3.0m COILED. FEED THROUGH HOLE IN THE RECESSED LIFTING DIVOT OF THE PULL BOX LID.
- ALL OPEN EXCAVATION AN CORING PERIMETERS ALSO APPLY.

CONDUIT INSTALLATION BY CORING

CONDUIT IS TO BE HDPE AND/OR BORE GUARD OR UNLESS OTHERWISE SPECIFIED ON CONSTRUCTION DRAWINGS:

- PLACEMENT WILL BE INDICATED ON DRAWINGS.
- RAILWAY, PIPELINE AND OTHER CORING DEPTHS WILL BE SPECIFIED ON DRAWINGS. DOCUMENTS WILL BE ISSUED AS REQUIRED.
- ALL FACILITY CROSSINGS ARE TO BE DONE AT 90 DEGREES WHERE EVER POSSIBLE.
- MINIMUM TW90#14 WHITE COPPER TRACER WIRE IS TO BE INSTALLED WITH ALL CORED CONDUIT.
- FIBER OPTIC MARKER TAPE IS TO BE INSTALLED WITH CONDUIT.
- HDPE MUST HAVE A PULL STRING INSTALLED TO PROVE CONTINUITY.
- ALL OPEN EXCAVATION PERIMETERS ALSO APPLY.

PULL BOX INSTALLATION

CONCRETE PULL BOXES ARE TO BE SUPPLIED BY D&M CONCRETE PRODUCTS:

- UNIVERSAL PULL BOX 40" W/H-20 WITH LID. E3500.PB4.
- LOCATION PLACEMENT OF PULL BOXES WILL BE INDICATED ON DRAWINGS, WITH A LOCATOR BALL PLACED INSIDE.
- PULL BOXES HANDLING/PLACEMENT METHOD - PULL BOXES TO BE LIFTED ONLY BY USING MANUFACTURES SPECIFIED LIFTING DEVICE.
- MINIMUM OF 305mm OF 25mm WASHED GRAVEL, DEPENDING ON SOIL CONDITIONS, IS TO BE PLACED UNDER PULL BOX AND EXTEND 300mm BEYOND SIDES.
- ALL PULL BOXES ARE TO BE SET WITH LIDS FLUSH WITH EXISTING OR FINAL SURVEYED GRADE, SIDEWALKS, CURBS OR AS SPECIFIED.

COMPOSITE PULL BOXES MAY BE SPECIFIED IN CERTAIN APPLICATIONS. MANUFACTURERS ARE SYNERTECH OR PENCELL (ANSI/SCTE 77-2007 TIER 22 STANDARDS):

- AVAILABLE FROM VARIOUS TELECOMMUNICATION SUPPLIERS.
- PULL BOX SIZE VARIES AND WILL BE SPECIFIED FOR VARIOUS APPLICATIONS.
- POLYMER/CONCRETE LIDS ARE TO BE MINIMUM ANSI/SCTE 77-2007 TIER 22 STANDARDS.
- INSTALLATION STANDARD IS TO BE FOLLOWED AS PER CONCRETE PULL BOX INSTALLATION AND AS PER MANUFACTURERS RECOMMENDATIONS. DRILL 1/4"(6.5mm) HOLE IN RECESSED LIFTING DIVOT OF THE LID.



**UNIVERSITY OF
CALGARY**

FACILITIES DEVELOPMENT

This is a copyright drawing and shall not be reproduced or revised without written permission and must be returned at completion of work or upon request.

The contractor shall check and verify all dimensions and report all errors and omissions to the architect prior to construction.

This drawing must not be scaled.

This drawing shall not be used for construction purposes until so approved.

no.	description	date (mm/dd/yyyy)

1. Issued for Design Standards			2019.11.27
no.	description	date (mm/dd/yyyy)	

project title
**FIBRE OPTIC CABLE
INSTALLATION**

drawing title
SPECIFICATIONS #1

project no. BASH190160	true north
scale AS NOTED	
drawn HD	
checked JW	sheet no.
plot date 2019.11.27	E4

