

5.17 Electrical Systems

Table of Contents

1	Sustainability Requirements for Lighting	P.2
2	Codes, Regulations and Standards	P.3
3	Design Criteria	P.5
4	Medium Voltage Distribution	P.9
5	600V Main Switchgears	P.10
6	Main Equipment Rooms – Electrical and Telecommunications	P.11
7	Secondary Branch Power distribution	P.12
8	Lighting, Exit Sign and Control	P.23
9	Voice and Data Distribution System	P.36
10	Emergency Power \ Generator Systems	P.36
11	Transfer switches	P.50
12	Clean Power System\ UPS system\K-rated transformer	P.55
13	Grounding System	P.59
14	Lightning Protection System	P.60
15	Security Systems	P.61
16	Short Circuit and Coordination Study	P.61
18	Spare Parts List	P.62
	Appendix I -VFD labelling	P.63



5.17.1 Sustainability Requirements for Lighting

1. Interior Lighting – Lighting Control:

- a. All individual occupied spaces (private offices, open offices, workstations) require individual lighting control that enables occupants to adjust the lighting to suit their individual tasks and preferences with a minimum of three lighting levels (on, off, and midlevel - between 30% and 70% of the maximum illumination level).
- b. All shared multi-occupant spaces must include all the following requirements:
 - i. Lighting controls that enable occupants to adjust the lighting to meet group needs and preferences, with at least three lighting levels (on, off, midlevel);
 - ii. Lighting with separate controls must be provided for any presentation or projection wall; and
 - iii. Switches or manual controls must be located in the same space as the controlled luminaires. A person operating the controls must have a direct line of sight to the controlled luminaires.

2. Interior Lighting – Lighting Quality

- a. All light fixtures (with the exception of wall wash fixtures) in regularly occupied spaces must have a luminance of less than 2,500 lumens/m² between 45 and 90 degrees from nadir.
- b. All light sources must have a CRI of 80 or higher. Exceptions include lamps or fixtures specifically designed to provide colored lighting for effect or other special use as approved by Campus Engineering.
- c. All light sources that have a rated life (or L70 for LED sources) of at least 24,000 hours (at 3-hour per start, if applicable).
- d. Use direct-only overhead lighting for 25% or less of the total connected lighting load for all regularly occupied spaces.
- e. All regularly occupied spaces must meet the following thresholds for area-weighted average surface reflectance: 85% for ceilings, 60% for walls, and 25% for floors.
- f. Furniture finishes must be selected to meet the following thresholds for area-weighted average surface reflectance: 45% for work surfaces, and 50% for movable partitions.
- g. All regularly occupied spaces must be designed such that the ratio of average wall surface illuminance (excluding fenestration) to average work surface illuminance does not exceed 1:10.
- h. All regularly occupied spaces must be designed such that the ratio of average ceiling illuminance (excluding fenestration) to average work surface illuminance that does not exceed 1:10.

3. Light Pollution Reduction:

- a. All exterior luminaires must not exceed the following up light ratings (based on the specific light source installed in the luminaire), as defined in IES TM-15-11, Addendum A:

- i. U2 for projects on main campus or foothills campus
 - ii. U1 for projects at the spyhill campus
 - iii. U0 for projects at satellite campuses (e.g. Barrier Lake Field Station, Rothney Observatory, R.B. Miller Field Station)
- b. All exterior luminaries must not exceed the following backlight ratings (based on the specific light source installed in the luminaire), as defined in IES TM-15-11, Addendum A:
 - i. B4 for projects on main campus or foothills campus
 - ii. B3 for projects at the spyhill campus
 - iii. B1 for projects at satellite campuses (e.g. Barrier Lake Field Station, Rothney Observatory, R.B. Miller Field Station)
 - iv. More stringent backlight ratings are required for exterior fixtures located less than 2 mounting heights from campus boundaries, consult with Campus Engineering and the Office of Sustainability for the specific standards to be applied in these cases.
- c. All exterior luminaries must not exceed the following backlight ratings (based on the specific light source installed in the luminaire), as defined in IES TM-15-11, Addendum A:
 - i. G2 for projects on main campus or foothills campus
 - ii. G1 for projects at the spyhill campus
 - iii. G0 for projects at satellite campuses (e.g. Barrier Lake Field Station, Rothney Observatory, R.B. Miller Field Station)
 - iv. More stringent glare ratings are required for exterior fixtures located less than 2 mounting heights from campus boundaries, consult with Campus Engineering and the Office of Sustainability for the specific standards to be applied in these cases.
- d. Internally illuminated exterior signage must not exceed a luminance of 200 lumens/m² (nits) during nighttime hours and 2000 lumens/m² (nits) during daytime hours.

5.17.2 Codes, Regulations and Standards

Comply with all applicable codes, regulations and standards. This list does not mean to restrict the use of additional codes, regulations or standards.

1. Canadian Standards Associations (CSA) Standards:
 - a. CSA- C22.1: Canadian Electrical Code, Part I, Safety Standard for Electrical Installations (CEC)
 - b. CAN/CSA C282: Emergency Electrical Power Supply for Buildings
 - c. CSA C802.2: Minimum Efficiency Values for Dry-Type Transformers
 - d. CAN/CSA-C802.3: Maximum Losses for Power Transformers
 - e. CAN/CSA-T530: Building Facilities, Design Guidelines for Telecommunications
 - f. CSA Z462: Workplace Electrical Safety Standard

2. Alberta Building Code
3. Alberta Fire Code
4. American National Standards Institute (ANSI)
5. ANSI/ASHRAE/IESNA Standard 90.1-2010: Energy Standard for Buildings Except Low- Rise Residential Buildings
6. National Energy Code of Canada for Buildings (NECB)
7. The Uniform Building and Accessibility Standards Act (Alberta)
8. The Occupational Health and Safety Act and Regulations (Alberta)
9. Illuminating Engineering Society of North America (IESNA)
10. Certified Ballast Manufacturers (CBM)
11. Institute of Electrical and Electronics Engineers (IEEE)
12. Electronic Industries Alliance / Telecommunications Industry Association (EIA/TIA) Standards:
 - a. EIA/TIA Standard 568: Commercial Building Telecommunications Wiring Standard
 - b. EIA/TIA Standard 569: Commercial Building Standard for Telecommunications Pathways And Spaces
 - c. EIA/TIA Standard 606: Administration Standard For The Commercial Telecommunications Infrastructure
 - d. EIA/TIA Standard 607: Commercial Building Grounding (Earthing) And Bonding Requirements For Telecommunications
 - e. EIA/TIA Standard 758: Telecommunication Standards for Customer Owned OSP
13. Building Industry Consulting Service International (BICSI)
14. National Fire Protection Association (NFPA) Standards:
 - a. NFPA 20: Standard for the Installation of Stationary Pumps for Fire Protection
 - b. NFPA 71: Installation, Maintenance, and use of Central Station Signalling Systems
 - c. NFPA 72D: Installation, Maintenance, and use of Proprietary Protective Signalling Systems
 - d. NFPA 72E: Automatic Fire Detectors
 - e. NFPA 70E: Standard for Electrical Safety in the Workplace
 - f. NFPA 96: Standard for Ventilation Control and Fire Protection of Commercial Cooking Operations
15. CAN-ULC Standards:
 - a. CAN-ULC-S524: Standard for the Installation of Fire Alarm Systems



- b. CAN-ULC-S525: Audible Signal Devices for Fire Alarm Systems, Including Accessories
 - c. CAN-ULC-S526: Visible Signal Devices for Fire Alarm Systems, Including Accessories
 - d. ULC-S527: Standard for Control Units for Fire Alarm Systems
 - e. CAN-ULC-S528: Manual Stations for Fire Alarm Systems, Including Accessories
 - f. CAN-ULC-S529: Smoke Detectors for Fire Alarm Systems
 - g. CAN-ULC-S530: Heat Actuated Fire Detectors for Fire Alarm Systems
 - h. CAN-ULC-S531: Standard for Smoke-Alarms
 - i. ULC-S533: Standard for Egress Door Securing and Releasing Devices
 - j. CAN-ULC-S536: Inspection and Testing of Fire Alarm Systems
 - k. CAN-ULC-S537: Verification of Fire Alarm Systems
 - l. CAN-ULC-S541: Speakers for Fire Alarm Systems, Including Accessories
 - m. ULC-S548: Alarm Initiating and Supervisory Devices for Water Type Extinguishing Systems
 - n. CAN-ULC-S552: Standard for Maintenance and Testing of Smoke-Alarms
 - o. CAN-ULC-S553: Standard for Installation of Smoke-Alarms
16. Electrical and Electronic Equipment Manufacturers Association of Canada (EEMAC)
17. National Electrical Manufacturers Association (NEMA)

5.17.3 Design Criteria

- 1. General
 - a. The electrical system shall be designed by a professional electrical engineer, licensed to practice in the province of Alberta.
 - b. The design criteria specified in this document provide minimum requirements.
 - c. Electrical systems shall be designed to meet the requirements of ANSI/ASHRAE/IESNA Standard 90.1.
 - d. Ensure sufficient space and access is provided around and above electrical equipment for safety, ease of maintenance and future component replacement. Allow sufficient space for cable bending radii and cooling requirement.
 - e. Arrange equipment and incorporate components into electrical systems to facilitate maintenance and commissioning.
 - f. When evaluating system alternatives, base discussions on life cycle cost analysis while maintaining the design intent.
 - g. Incorporate cost effective energy conservation measures that do not diminish building performance or occupant comfort.



- h. Electrical and communications systems shall provide sufficient capacity for increased load concentrations in the future and allow modifications to be made in one area without causing major disruptions in other areas of the facility.
- i. The U of C requires the integration of Building Automation Systems (BAS) to monitor and control heating, ventilating and air conditioning. Lighting control should be done through a separate monitoring system. Fire alarm, security and security systems shall function as stand-alone systems with a monitoring only interface to the BAS. PowerLogic systems should be connected to the ION Enterprise system (Refer relative section 1.17.3 and 1.17.4 for specific metering requirement)
- j. Provide a "Safe T Sensor" on every microwave installed in new or retrofit projects. Detail cut sheet for Safe T Sensor could be referenced on web: <https://www.pioneeringtech.com/store/commercial/safe-t-sensor/>

2. Electrical System Design Parameters

- a. In establishing electrical load for the University of Calgary, it is important to look beyond the immediate requirements stated in the project program.
- b. Unless the load requirements stated in the project program are higher, the minimum connected loads, indicated in the following tables, combined with other building loads adjusted by appropriate demand factors, and with spare capacity added, shall be used for obtaining the overall electrical load of the building.

Lighting Demand for Electrical Load Sizing (extracted from NECB)	
Area / Activity	*Design Lighting Demand (W/m²)
Office Enclosed	11.9
Office Open	11.0
Conference Meeting / Multipurpose	13.2
Classroom / Lecture / Trainings	13.3
Lobby	9.7
Atrium	0.1/m (height)
Lounge / Recreation	9.4
Dining Area	7.0
Food Preparation	10.7
Restrooms	10.5
Corridor / Transition	7.1 (>2.4m wide); 8.4 (<2.4m wide)
Stairs	7.4
Active Storage	6.8
Electrical / Mechanical / Telecom Rooms	13.4

*Based on NECB 2011 Space-by space Method

Minimum Receptacle Demand for Electrical Load Sizing		
Area / Activity	Service Equipment (VA/m²)	Distribution Equipment (VA/m²)
General Purpose Systems		
Office Enclosed	14	27
Office Open	14	35
Non-Workstation areas	5	10
Core and Public areas	2.5	5
Electronic Systems		
Office / Enclosed	13	32
Office Open	13	43
Technology / Server Rooms	540	700

- c. Loads associated with motors and equipment must use the rated brake horsepower of specified equipment.
 - d. Elevator loads must use the rated brake horsepower of the specified equipment. Demand factors identified in the Canadian Electrical Code, Table 62, shall be included.
 - e. Additional miscellaneous loads, e.g. Security, Communication, Alarm Systems, Heat Tracing, Kitchen Equipment, Central Computer Servers, existing and new site power and lighting, etc., shall also be included.
3. Standard for Sizing Equipment and Systems
- a. To ensure maximum flexibility for future systems changes, the electrical system must be sized for the demand load with additional spare capacity as follows:
 - i. Panelboards for branch circuits: 50% spare ampacity as 25% spare circuit capacity.



- ii. Panelboards serving lighting only: 25% spare ampacity as well as 25% spare circuit capacity.
 - iii. Switchboards and distribution panels: 35% spare ampacity and 25% spare circuit capacity.
 - iv. Main Switchgear: 25% spare ampacity and 25% spare circuit capacity.
 - b. Spare overcurrent devices shall be provided as well as bus extension for installation of future protective devices. As a minimum, one spare breaker of each frame sizes, excluding the Main-Tie-Main, shall be provided.
 - c. Prior to adding the spare equipment ampacity to account for future load growth, it is important that the load study reflect actual demand loads rather than connected loads. The designer shall apply realistic demand factors by considering various energy conserving devices such as variable frequency drives applied to brake horsepower, energy efficient motors, occupancy sensors, etc. The designer shall also avoid adding the load of stand-by motors and shall be careful to distinguish between summer and winter loads by identifying such “non-coincidental” loads. Once the estimated “peak demand” load is established then the factor for load growth shall be added.
4. Utility Coordination
- a. A detailed load study, including connected loads and anticipated maximum demand loads, as well as the estimated size of the largest motor, shall be included in the initial contact with the U of C Electrical Utilities to prepare them for discussions relative to the required capacity of the new electrical service.
 - b. Locations of transformers, vaults, meters and other utility items must be coordinated with the architectural design to avoid conflicts with critical architectural features such as main entrances and must consider both equipment ventilation and equipment removal. Consideration for cable bending radii shall also be included.
 - c. Concrete-encased Rigid Type DB2/ES2 PVC ductbanks shall be used where many circuits follow the same route, for runs under permanent hard pavements and where service reliability is paramount, such as service entrances and medium voltage cables.
 - d. Concrete encased ducts shall be provided with a cover of at least 1000 mm. Ducts shall slope toward manholes. Changes in direction shall be by sweeps with a radius of 7.5 m or more. Stub-ups into electrical equipment may be installed with manufactured elbows, minimum 100 mm above housekeeping pads. Duct line routes shall be selected to avoid foundations of other buildings and other structures. Electrical and communication ducts shall be kept clear of all other underground utilities, especially high temperature water or steam.
 - e. Direct buried conductors, cables and raceways shall be installed with minimum cover as per CEC table 53.
 - f. All underground installations shall have a warning tape buried at about 300 mm below finished grade.



- g. Where it is necessary to run communication cables parallel to power cables, two separate systems must be provided with separate manhole compartments. The same holds true for normal and emergency power cables. Duct banks shall be spaced at least 300 mm apart.
- h. Ducts shall be sized as required for the number and size of cables. All ducts for medium voltage services (13.2 kV) shall be a minimum of 155 mm. Inner ducts must be provided inside communication ducts wherever fibre optic cables will be used. A minimum of four spare ducts shall be included for future expansion.
- i. Manholes shall be spaced no farther than 150 m apart for straight runs. The distance between the service entrance and the first manhole shall not exceed 30 m. Double manholes shall be used where electric power and communication lines follow the same route. Separate manholes shall be provided for low and medium voltage systems. Manholes shall have clear interior dimensions of no less than 1800 mm in depth, 1800 mm in length, and 1800 mm in width with an access opening at the top of not less than 750 mm in diameter. Medium voltage manholes shall be sized in accordance with the U of C Electrical Utilities requirements. Manholes must have a minimum wall space of 1800 mm on all sides where splices are to be racked. Manholes shall be provided with pulling eyes, sumps and grounding provisions as necessary.
- j. Minimum of two spare stubs shall be provided (to maintain a square or rectangular ductbank) so that the manhole wall will not need to be disturbed when a future extension is made. Stubs for communications manholes must be coordinated with the U of C Information Technologies.

5.17.4 Medium Voltage Distribution

1. Medium Voltage Switchgear

- a. Design of the medium voltage switchgear shall meet all of the requirements of the U of C Electrical Utilities. Switchgear assembly shall be metal enclosed rated for indoor or outdoor installation as required, c/w lightning arrestors in outdoor installations.
- b. Incoming utility entrance modules shall be provided with three-pole fast acting single blade design load break disconnect switches. 600 A continuous minimum with a mechanical interlock so that the switch must be open before the door can be opened and the door must be closed before the switch can be closed.
- c. Feeder modules shall be provided with three-pole fast acting single blade design load break fused disconnect switches. 400 A continuous minimum. Power Fuses shall be provided for all transformer feeders. Non-removable operating handle c/w Kirk key interlock where required.
- d. Bussing shall be copper only; aluminum bussing will not be accepted.
- e. Grounding balls c/w ground studs, 3 Ø set.
- f. Hawk IR Infrared windows, model 19251-000, for each blade and fuse section.
- g. Design to consist of non arc blade and arc chute type.
- h. Blades and fuses shall be visible from the front.



- i. 100 W lamp in porcelain holder c/w wire guard in each module, with externally mounted watertight switch. 120 VAC circuit to be from an emergency power source.
 - j. Front access only.
 - k. Acceptable manufacturer: S&C or approved alternate.
2. Medium Voltage Conductors
 - a. Conductors shall be copper, insulated with cross linked polyethylene (XLP) or ethylene propylene rubber (EPR). Insulation shall be rated at 133 percent. Conductor size shall not exceed 350 kcmil. In general U of C ring mains are 350 kcmil, transformer feeders are 2/0 AWG and main feeders are parallel 350 kcmil.
 3. Medium Voltage Transformers
 - a. Substation transformers shall be dry-type with epoxy resin cast coils. Substations shall be located at least 30 m from communications frame equipment to avoid radio frequency interference. Provide surge suppression on the secondary and/or downstream busses.

5.17.5 600V Main Switchgears

1. All main, tie and secondary feeder breakers shall be draw-out air-circuit type. They shall be built to be field maintainable and serviceable. Switchgear shall be front and rear accessible (for free standing only), with hinged lockable doors. Aluminum bus will not be acceptable.
2. Each main service switchboard shall contain a digital meter in compliance with section 5.24 Metering Systems for Campus Infrastructure, complete with PT, CT and all necessary accessories. It shall be eligible for ION software. All meters shall come with Ethernet/RS485 communication port for remote monitoring. Include an Ethernet/data port connection RJ45 within the same room to tie into the U of C network. Consult the U of C Electrical Utilities department (EUD) in case of query.
3. All breakers in the 600 volt rated service main switchgear shall be fully rated. Series rating will not be permitted for this equipment. Main, tie and feeder breakers shall be provided with integral solid-state tripping elements, including Long Time, Short Time, Instantaneous and ground-fault protection (L.S.I.G.). Provision shall also be included to allow for a service mode settings that will increase the Arc Fault protection by lowering the energy level. Provision for future remote control shall also be included.
4. Substation secondary switchboards shall be freestanding and shall be provided with a single main service disconnect device. This main device shall be insulated case, power air circuit breaker or bolted-pressure fusible switch (where appropriate), shall have ground fault protection, and shall be individually mounted, draw-out type (as applicable). Insulated case and power air circuit breakers shall be electrically operated. Branch feeders shall be protected, either by fusible load-break switches or fully rated molded case circuit breakers. Front access only will be acceptable. Aluminum bus will not be acceptable.
5. Provide surge suppression on the main incoming service secondary switchboard.
6. The U of C preferred layout is to have one transformer located on either side of the 600 V Main Switchgears.

5.17.6 Main Equipment Rooms – Electrical and Telecommunications

1. The main switchgear room must be located securely in a vault or inside the building along a perimeter wall at an elevation that minimizes the transformer secondary feeder lengths. Main switchgear room doors shall be large enough (width and height) to allow for the removal and replacement of the largest piece of equipment. Both equipment and man doors shall swing out and be provided with panic hardware. The size and location of the Telecommunications Service Room shall be established in concert with the U of C Information Technologies and shall be provided with 24-hour HVAC service and protected from contaminants by proper filtration equipment.
2. Electrical rooms shall be generally located within the core areas of the facility and shall be stacked vertically. Adequate numbers of electrical rooms shall be provided such that no electrical room serves more than 930 m². Electrical rooms shall be provided with minimum clear dimensions of 1.8 m by 3 m, with 4.3 m ceiling height. If transformers are located in the rooms, ventilation must be provided. Doors shall swing out.
3. Communications rooms shall also be generally located within the core areas of the facility and shall be stacked vertically. Rooms shall be sized to contain adequate floor space for frames, racks and working clearances in accordance with (EIA/TIA) standards. Provisions shall be made for air conditioning these rooms.
4. Main and sub-electrical/communication rooms shall be provided with cooling to cope with ventilation requirement to guarantee maximum performance of switchgears, transformers and communication equipment (Refer to UCIT design guide on heat dissipation). Incorporate and collaborate this requirement with mechanical designing the rooms.
5. Where cooling or nearby water pipe exist inside electrical / communication room, precaution shall be taken such that no condensation or pipe leakage would result. In general, no water pipes are allowed above the switchboard or power distribution panel. Where existing pipes are unavoidable, a drip pan along the whole length of the switchgear shall be provided to divert the water away and any openings/penetration through top of the switchboard / switchgears by feeders shall be liquid-tight and sealed.
6. Spaces for Uninterruptible Power Systems (UPS) and Batteries. The requirement for a UPS system will be a tenant based requirement. In order to establish the proper size, location and environmental requirements for the system, the designer shall arrange to meet with the architect and a representative of the tenant to determine the required/estimated load and physical size requirements, and nature of the critical loads. Refer to the UPS and battery manufacturers' installation instruction for weights, dimensions, efficiency, and required clearances in the design.
 - a. For small systems, up to 50 kVA, the UPS modules and sealed cabinet batteries shall be installed in the room with the equipment being served.
 - b. For medium and large systems, greater than 50 kVA, the UPS system shall be provided with standby generator back-up to limit the battery capacity. The UPS system equipment and batteries shall be in separate rooms, located on the lowest level, because of the weight of the batteries and the noise of the UPS equipment.
 - c. Batteries shall be sealed Lead-Acid, non gassing type.



7. Allow space for storage of safety equipment (this location to be located outside of this room in the event of a fire and or battery explosion) such as goggles and gloves. Special attention shall be given to floor loading for the battery room, entrance door dimensions for installation of the UPS and ceiling height for clearance of the appropriate HVAC systems and exhaust systems. An emergency shut off switch is to be located outside of this room to shut off power to the ups in the event of a fire.

5.17.7 Secondary Branch Power Distribution

1. Bus Duct

- a. Bus ducts shall be copper, fully rated, 3-phase, 4-wire with 100% neutral and an integral ground bus, sized at 50 percent of the phase bus. Provide calculations supporting the specified short circuit rating.

2. Conductors

- a. The base bid specifications shall require that copper be utilized throughout, including motor windings, transformer windings, switchgear bussing, switchboard and panelboard bussing, bus duct, primary and secondary feeders, branch feeders, and branch circuits. Aluminum is not permitted.
- b. Distribution conductors shall be RW90, XLPE, minimum #12 AWG for all branch circuits and minimum #14 AWG for control wiring only.

3. Motor Control Centres (MCC)

- a. Grouped motor controls shall be used where eight (8) or more starters are required in an equipment room. Motor control centre (MCC) construction shall be NEMA Class I, Type B, copper, with magnetic (or solid state if appropriate) starters and moulded case circuit breakers. Minimum starter size in motor control centers shall be Size 1. Control circuit voltage shall be 120 V connected ahead of each starter via a fused control transformer. Control transformer shall be located inside motor starter cubicle. Reduced voltage starters may be used for larger motors to reduce starting kVA.
- b. Time delay relays shall be incorporated in the starters or programmed in the BAS system to reduce inrush currents on the electrical system.
- c. VFD's are not to be mounted in MCC'S, or on fan walls that can generate and transfer vibrations to the VFD. In general, VFD shall be mounted independently and close to the motor, both in the same room.

4. Starters

- a. All starters are to be NEMA, Class 1 rated, not IEEE. Starters are to be combination type complete with breaker or fusible disconnect, 2 sets of NO/NC contacts. Magnetic starter with HOA controls would be on front of starter. Control transformer shall be 45VA minimum output and a secondary control voltage of 120V AC. Transformer to be fused on primary and secondary side. Acceptable manufacturers for MCC and starters are:
 - i. Square D
 - ii. Allen Bradley
 - iii. Eaton/Cutler Hammer

5. Elevator Power

- a. It is recommended that the load of the elevator feeders be divided among the secondary switchgears, provided that there are 2 or more switchgears, and that alternate elevator machines shall be fed from different switchgears.
- b. One (1) elevator in each bank shall be connected to the emergency generator. Where multiple elevators are in a common bank, provide a common emergency feeder from the Elevator ATS to allow each elevator to be operated individually during an emergency. By interlocking the ATS with the elevator group controller, programming shall be made by the elevator supplier to set up a controlled return to the terminal floor and then limit the number of elevators in that bank that can be run.
- c. Elevator machines shall be powered from circuit breakers with a shunt trip and with padlocking capability, located in the elevator machine rooms. Electrical design standards in Elevator Standard ASME A17.1/CSA B44 shall be followed.

6. Variable Frequency Drives (VFD)

- a. In general, VFD enclosures can be NEMA 1 when installed indoors and in dry locations. However, a NEMA 12 enclosure is required where:
 - i. Sprinklers and/or water shut off valves are above the VFD
 - ii. There is water in the vicinity of the VFD that could cause damage to the VFD due to a pipe or valve leak

Contractor/Consultant shall visit site and identify the above risk with U of C Facilities prior to installation.

- b. All VFD's shall come with a disconnect built in the drive (integral) for power isolation and servicing to meet code requirement CEC 28-604
- c. VFDs are now in general use on all projects by virtue of their contribution to the energy efficiency of the project. They also generate harmonics which are injected into the secondary power distribution system and need to be minimized through the use of filters tuned to the peak harmonic generated by the drive.
- d. Provide AC line reactor external and upstream of the VFD. See flow chart below to determine the size and type.

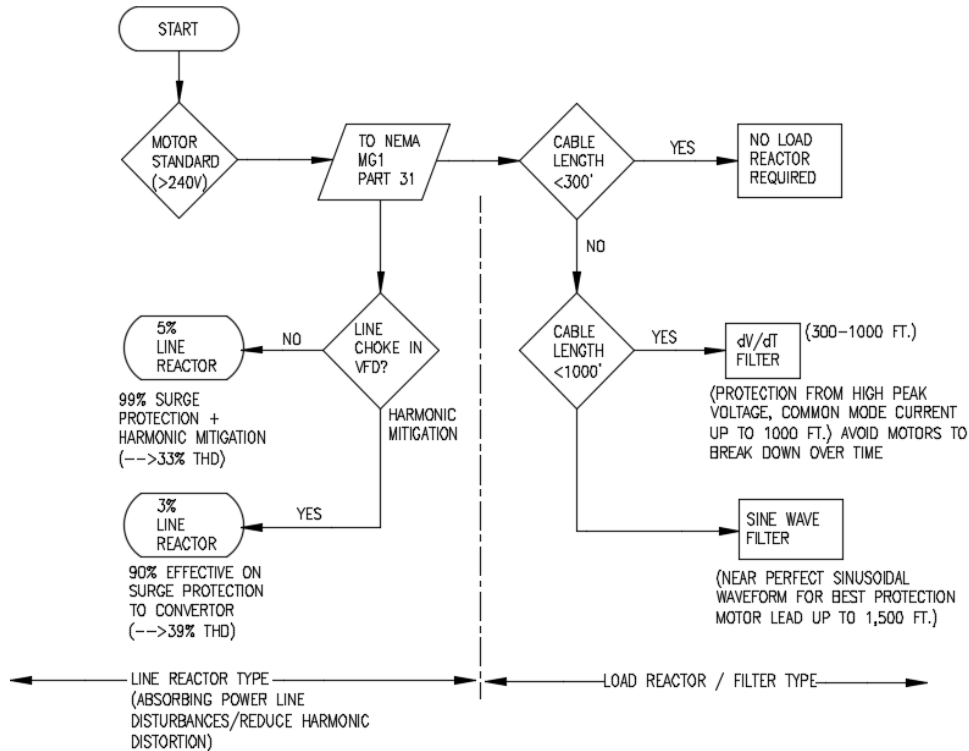

- e. Alternatively, a VFD can have a dual 5% impedance DC link reactor on the positive and negative rails of the DC bus to minimize power line harmonics and protect the VFD from power line transients. VFDs with 3% impedance DC link reactors shall require an additional 3% AC line reactor to provide acceptable harmonic performance at full load (unless the internal DC link reactor could provide harmonic mitigation equal to or better than a 5% external line reactor).
- f. Load reactor/filters external to VFD are also required in most situations. Refer to the flow chart to determine the size and type if it is required.
- g. Overcurrent protection

DC choke does not provide protection to the diode at the front end of the drive from voltage transients on the AC supply voltage. Due to this reason, additional input transient voltage protection must be provided, such as surge suppressor like the fast acting Metal Oxide Varistor Bridge (MOV). VFDs shall utilize a minimum 6-pulse, pulse width modulation (PWM), design. VFDs shall be specified with passive harmonic filters. VFDs shall also be specified with isolation transformers where required. Specify thermal sensors that interlock with the VFD control circuit for additional solid state motor protection for motors running at low speeds and subject to overheating. This is in addition to the standard over-current protection required.

VFDs shall be designed to operate standard squirrel cage induction motors with a 1.15 S.F. or definite purpose motors meeting NEMA Standard MG1 Part 31 and all products shall comply with IEEE Standard 519. Drive output shall be sized for a 1.0 motor service factor.



- h. VFD selection shall be based on load current at constant torque ratings. DO NOT SIZE VFDs BASED ON VARIABLE TORQUE MAXIMUMS.
- i. Manufacturers: The following manufacturers and models of VFDs are acceptable. No substitutions will be accepted. No “micro-drives”:
 - i. ABB (ACH 550) or ACH580
 - ii. Toshiba AS1 (for 575V application); Toshiba AS3 (for 208V application)
 - iii. Danfoss (VLT Series)
- j. VFDs or VFD bracing shall not be mounted on high vibration surfaces such as plenum walls. Proper vibration isolation must be maintained at all times.
- k. Integrated drives on pumps shall not be accepted.
- l. VFDs shall be mounted at normal working height to allow for maintenance and repair without requiring ladders, scaffolds or movable platforms.
- m. The U of C operational requirements (“Critical Installs”) require that full voltage bypass be installed on VFDs when they affect any system or component critical to:
 - i. Building operation
 - ii. Building occupancy
 - iii. Personal health and safety
 - iv. Animal health and safety
 - v. Environmental concerns
 - vi. Research operations
 - vii. Asset protection
 - viii. Emergency response plans
- n. Critical installs to include a 3 contactor bypass system (or 2 contactor bypass with drive isolation disconnect switch) using NEMA or IEC rated contactors. Critical installs shall include any system or component that would adversely affect building occupancy, health & safety, animal care, environment, research or asset protection if the VFD failed. Critical installs of 100 HP or larger shall be provided with bypass system installed with soft start devices or similar technology such that the motor could be started effectively with manageable inrush current.
- o. The 3 contactor bypass isolates the load and line side of the drive but allows the motor to be powered up at full speed (60Hz). The bypass must use a keypad so that it is not used until required and by authorized personnel only. Bypass system must provide overload protection as well as system control points for enable, status, freeze stat, vibration, end damper, fire alarm control, etc. Provide VFD/OFF/Bypass selector switch.
- p. The use of a full voltage bypass may be omitted in the following conditions:
 - i. Where there is a standby or redundant unit, e.g. primary and secondary heating pump.
 - ii. Where units are connected to a common header or system and loss of one unit



can be managed and compensated by the other unit(s). Alarming is then required.

- iii. Where the unit is not critical to any of the 8 criteria listed in item r. above.
- q. Provide lamacoid nameplates for VFD drives which shall include:
 - i. VFD name as assigned in the design
 - ii. Electrical circuits where it is fed from
 - iii. Control panel name where the VFD is tied to
- r. Shut down labels are also required to be installed on all drives, disconnects and starters, indicating the safe shut down and maintenance procedures as detailed in **Appendix I** at end of this standard.

7. Motors for VFD Applications

- a. All motors connected to VFDs shall be manufactured in accordance with NEMA Standard MG-1, Part 31, inverter duty class. Motors that only meet a specific section or partial MG-1 Part 31 standard shall not be accepted.
- b. Motors connected to VFDs shall have a Service Factor of 1.15 in a 40°C environment.
- c. Temperature rise will be Class B
- d. Motor selection shall be reviewed by VFD supplier.
- e. Motors shall be intended for varied operation over the defined speed range and not for continuous operation at a single or limited number of speeds.
- f. Motors shall be suitable to be operated continuously at any single speed within the defined speed range.
- g. The maximum temperature rise of the windings, above ambient temperature, shall not exceed the values given in Table 31-2, adjusted for an altitude of 3650 feet, when tested at any rated load within the rated speed range with the identified VFD. The temperature attained by cores, squirrel-cage windings, and miscellaneous parts shall not injure the insulation of the motor in any respect.
- h. Motors should be capable of producing a breakaway torque of at least 140% of rated torque requiring not more than 150% rated current when the voltage boost is adjusted to develop rated flux in the motor and when the VFD is able to produce the required minimum fundamental frequencies.
- i. The breakdown torque at any frequency within the defined frequency range shall be not less than 150% of the rated torque at that frequency when rated voltage for that frequency is applied.
- j. Motors shall be wound using inverter spike resistant magnet wire rated for 3.1 times the rated line-to-line voltage.
- k. Shaft grounding brushes shall be used to divert the induced voltage potential between the rotor and stator.
- l. Wring from the secondary of the VFD to the motor is to be 1000 volt rated cable.



- m. Nexans DriveRx VFD cable is to be used.
- n. VFD cables shall be secured with brackets no more than 1.5m apart, with closer spacing required if sagging is noted. Unistrut or cable tray **MUST** be used to support cable run where 3 or more VFD cables are running together.
- o. Acceptable Motors to be:
 - i. Toshiba
 - ii. Hyundai
 - iii. Westinghouse Optim HE
 - iv. WEG
 - v. US Motors
 - vi. Marathon
- p. TEFC motors are preferred over ODP type motors.

8. Circuit Loading

- a. 120 V lighting circuits shall be limited to a maximum of 1200 VA, on a 15 A breaker and 1700 VA on a 20 A breaker.
- b. 347 V lighting circuits shall be limited to a maximum of 3900 VA on a 15 A breaker and 5300 VA on a 20 A breaker.
- c. 120 V circuits for convenience receptacles shall be limited to a maximum of 1400 VA on a 15 A breaker and 1900 VA on a 20 A breaker, using 5-20RA type receptacles.
- d. Each special purpose receptacle shall be circuited on a dedicated circuit to a protective device to match the rating of the receptacle.

9. Wiring Devices

- a. In U of C buildings, general wiring devices shall be specification grade.
- b. Emergency receptacles shall be red.
- c. Isolated ground receptacles shall be orange.
- d. Special purpose receptacles shall be brown.
- e. The colour of standard receptacles and switches shall be coordinated with the architectural color scheme; for example, white, not ivory, devices shall be used if walls are white or light gray.
- f. Building standard receptacle shall be duplex, specification grade NEMA 5-15R.
- g. Housekeeping receptacle shall be duplex, specification grade NEMA 5-20RA, protected by a 20A rated circuit breaker.
- h. In general, switches and control (Lighting switch, fire pull stations, thermostats etc.) shall be mounted all at 1200mm AFF. Receptacles shall be at +300mm AFF. Consultant shall have these mounting heights updated prior to issuance of design if their company standard conflicting these.



- i. Special purpose receptacles shall be provided as required.
- j. Device cover plates shall be stainless steel.
- k. Receptacles in corridors shall be located 15 m on center and 7.5 m from corridor ends.
- l. Receptacles for housekeeping shall be placed in exterior walls and walls around permanent cores or corridors.
- m. Acceptable manufacturers: Hubbell and Leviton.
- n. A safe T sensor shall be included and provided by the contractor (Also refer to Design Criteria 5.17.3.1-j) which plugs in every receptacle designated for Microwave oven such that when smoke is detected due to overheating, the sensor attached to the machine will trigger the plug adaptor to cut off power to the Microwave.

10. Raised Access Floor

- a. All wiring beneath a raised access floor shall be routed in EMT conduit to underfloor distribution boxes and liquid tight flexible conduit to equipment and outlets. One distribution box per bay is recommended. Flush-mounted access floor service boxes shall be attached to the underfloor distribution boxes by means of a modular, prewired system to facilitate easy relocation.

11. Electrical and Telecommunication Rooms

- a. Electrical rooms require one emergency power receptacle that is identified as Emergency Power at the receptacle. The telecommunications room will contain power and grounding for the passive and active devices used for the telecommunications system, including at least two dedicated 20 A, 120 volt duplex electrical outlets on emergency power, and additional convenience outlets at 1.8 m intervals around the walls and direct connection to the main building grounding system. If uninterruptible power is required in telecommunications rooms, it will be furnished as part of the telecommunications system.
- b. Refer to paragraph 1.2.5.4 for cooling requirement.

12. Main Mechanical and Electrical Rooms

- a. Main mechanical and electrical equipment rooms shall each have, at a minimum, one emergency power receptacle that is identified as Emergency Power at the receptacle. Lighting switches shall be manual. Occupancy sensor lighting control is not allowed.

13. Exterior Mechanical Equipment

- a. Provide one receptacle adjacent to mechanical equipment exterior to the building, including each roof. Receptacles shall be of the weatherproof GFCI type. Receptacles must be located within 7m of each piece of equipment. If installed on roof, it shall not be less than 750mm above finished floor.

14. Washrooms

- a. In general, each washroom shall have
 - i. at least one convenience GFCI receptacle at low level for general maintenance.
 - ii. no receptacles required above vanity or countertop (except in student residence

application)

- b. Carefully coordinate the location of the receptacles with all toilet accessories.
- c. Low voltage cabling for hands free control for flushing appliances shall be run in EMT or armor cable secured to building lines. Power supply for LV cables shall be accessible and serviceable at ceiling hatch location.

15. Panelboards

- a. All panelboard interiors above 225 amps shall be constructed using hard-drawn copper of 98% conductivity, with aic bracing greater than the calculated available fault current. Panelboards 225 amps and under to be silver plated copper bussing with aic bracing greater than the calculated available fault current. Minimum short circuit rating for 208/120 V panelboards shall be 10,000 amperes symmetrical. Minimum short circuit rating for 600/347 V panelboards shall be 14,000 amperes symmetrical. A 200% neutral shall be provided for panelboards serving office loads served from the secondary sides of K-rated transformers or harmonic cancelling transformers. A full size copper ground bus for connecting ground conductors shall be bonded to the steel cabinet. Provide isolated ground bus where required. Panelboards whenever possible must match base building panelboards unless base building panelboards are no longer available.
- b. Branch circuit breakers shall be bolt-on designed for replacement without disturbing adjacent units. Breakers shall comply with the requirements of CAN/CSA 22.2 NO. 5, thermal magnetic type with short-circuit rating greater than the calculated available fault current. Panels shall be specified with “door-in-door” trim.
- c. Whenever new panelboards are installed on non-structural surface (drywall), a 21mm minimum thickness plywood backboard shall be provided to support the panel. Plywood shall be secured to studs or structure with fire-retarded paint as specified in other section of this standard.
- d. Splicing inside electrical panel is not acceptable (despite the code allows it under certain circumstances) unless permission is obtained from Campus Engineering due to site constraints.

16. Power Distribution Panels

- a. In general, circuit breaker type panels will be the standard of construction for U of C buildings. With the exception of lighting and receptacle panelboards, fusible switches may be considered if specific design considerations warrant their application, such as in electrical coordination of electrical over-current devices.
- b. Renovated space in existing building: new panelboards introduced shall match and be of same manufacturer as existing installed in the base building, unless otherwise approved by the University.
- c. New buildings and construction: new panelboards of acceptable type could be used. Acceptable panelboards to be:
 - i. Eaton/ Cutler Hammer
 - ii. Square D
 - iii. Siemens

17. Lighting and Receptacle Panelboards

- a. Lighting and receptacle panelboards shall be bolt-on type circuit breaker type. Tandem type circuit breaker will not be accepted. Provide minimum 30 poles for 100 amps panelboards and minimum 42 poles for 225 amp panelboards.
- b. Drip shields shall be provided where sprinklers are installed. Sealed connectors shall be used for all top-entry conduits.
- c. Panel boards are not allowed to be located behind doors, in vestibule, staircase, inside closet (except assigned as electrical closet) or other areas prohibited by Code(s).
- d. A minimum of 1000mm (3 feet) in front and around the panelboard shall be maintained.
- e. Spare circuit breakers equivalent to minimum of 10% for each type of breaker used in the panel shall be provided (may be included in the spare circuits as stipulated in Design Criteria 3.a i and ii)

18. Fire alarm system

- a. Smoke and Fire Detectors shall be installed as per the latest version of the Alberta Fire Code and Alberta Building Code. The University may, at its discretion, have additional detectors added in locations that they deem to be higher hazard. The following shall be additions to the current Code:
 - i. Smoke detectors in electrical rooms and data/IT closets.
 - ii. Smoke detectors in utility and storage rooms.
 - iii. Heat detectors in Care taking rooms.
 - iv. Heat detectors in all office kitchens / Kitchenettes.
- b. Where an Automatic Transfer Switch (ATS) exists in a project, a trouble signal shall be provided in the FACP. This must be tied to the BMS system so Facilities Maintenance can address ventilation system issues caused by the switch to emergency power.
- c. If Smoke Sensors are required in the design to fulfil smoke/fire dampers closure in a duct per ABC(AE) 3.1.8.11, the smoke detector is to operate as part of the damper system and is not to connect to the FAS. At every location where there are smoke/fire dampers as required by the Code, a status control panel equal to Greenheck test switch GTS-4 shall be installed and connected to the dampers, with a green (damper open) and red (damper closed) indication light visible from below the ceiling. The control panel shall be flush mounted in compatible back box on ceiling (ceiling or wall mounted to be coordinated on site)



GTS-4

Model (Voltage)	Part Number
GTS-3 (120V)	837641
GTS-3 (24V)	843122
GTS-4 (120V)	829807
GTS-4 (24V)	843123

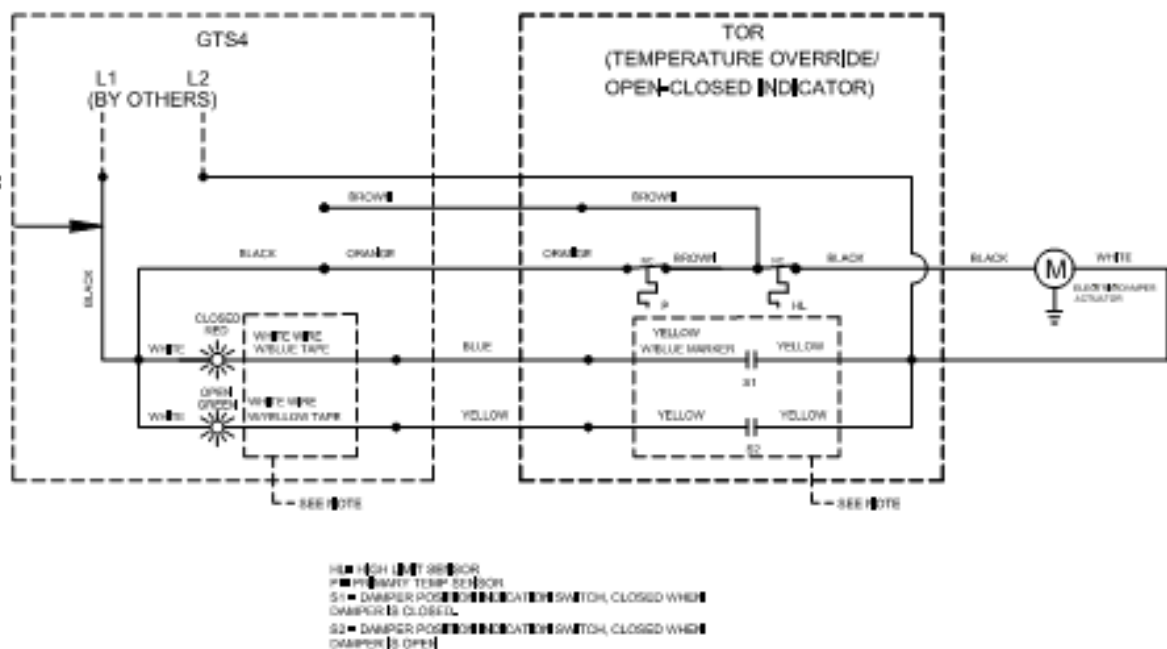

19. Emergency power-off (EPO) buttons

- a. In some projects, emergency buttons are provided by the room entrance to cut off power and gas supply to the laboratories in case of accidents or chemical spills in rooms. In general, the control circuit shall be designed such that power and gas supply will not be restored “automatically” once the EPO is activated or pressed. System could only be restored with authorization and reset. This “held open” mechanism may intervene some equipment in the laboratory which requires non-interrupted power supply such as fridges (for storing samples). Designers shall collaborate with end user on the nature of the laboratories and identify the critical equipment such that they will not be affected by the provision of EPO.

20. Conduit Systems

- a. The specification shall list the various types of conduit systems which are approved for use on the project and the specific raceway applications for which they are to be used, in

accordance with the Canadian Electrical Code.

- i. RSC Rigid galvanized steel conduit – CSA C22.2 No. 45.1/ANSI C80.1 Exposed outdoors
 - ii. IMC Intermediate steel conduit – ANSI C80.6 Indoor feeders – exposed and/or concealed
 - iii. EMT Electrical Metallic Tubing (compression fittings) – ANSI C80.3 Branch circuit wiring, exposed and/or concealed
 - iv. FMC Flexible metal conduit and or AC90 – connections to recessed lighting fixtures, 3 metres maximum length, and concealed in movable wall partitions
 - v. LFMC Liquid Tight Flexible metal conduit with PVC jacket. Connections to vibrating equipment (motors, transformers, etc.) and for installation “fished” into existing walls.
 - vi. EB1 – Rigid PVC – For encasement in concrete or masonry. Indoors and outdoors.
 - vii. DB2/ES2 – Rigid PVC – Direct burial or encasement in concrete or masonry.
- b. Minimum size of EMT used shall be 21mm (3/4”).
 - c. Vertical drop of wall receptacles in finished areas shall be in EMT. BX cables not allowed.

21. Equipment Marking and Identification

- a. All equipment must have a lamacoid plate attached to the front face of the equipment, stating the equipment ID, Voltage, Phase, Fed From, and amperage:
 - i. Distribution centres, switchgears and disconnects
 - ii. Transformer (also indicate the kVA, primary and secondary voltage)
 - iii. Starters, contactors,
 - iv. Panelboards
 - v. Automatic transfer switch, generator distribution
 - vi. Terminal cabinets and pull boxes
- b. Lamacoid name plates shall be 3mm thick x 100mm long plastic with beveled edge. 7mm high lettering (1 or 2 lines of text), black face (red for fire alarm and emergency system), white core, mechanically attached with self-tapping screws.
- c. Major system junction boxes e.g. fire alarm, security, communication shall be labelled with either a lamacoid plate and or Brother type labelling. Color coding of boxes shall be provided matching existing (for existing building) or per consultant’s specification (new building).
- d. Wiring devices shall be identified using Brother Labels with black lettering on clear tape in occupied spaces and black lettering on white tape in other areas. Labels shall indicate the panel and circuit number.

5.17.8 Lighting, Exit Sign and Control

1. The lighting and daylighting systems of a building represent one of the most critical



components to the architectural aesthetic, the successful completion of tasks, and the annual energy consumption of the building. In order to effectively address all these concerns, the lighting systems must be sensitive to the interior and architectural design while providing an adequate quality and quantity of illumination throughout the building. Yet, the lighting system must maintain an energy efficient design that, at minimum, meets ASHRAE/IES 90.1 lighting power density requirements. In addition, the lighting design shall attempt to minimize maintenance requirements.

2. General Lighting Design Criteria

- a. The electric lighting design criteria are intended to ensure sufficient visual comfort and performance of the lighting environment provided by the electric lighting systems. Lighting designs must minimize harsh contrasts by employing a combination of direct and indirect lighting sources. This can be accomplished through the use of indirect/direct lighting systems, wall sconces or a combination of uplighting and downlighting. In addition, vertical surface illumination shall be considered, where applicable. Task/ambient lighting strategies are designs that break down the lighting system by the lighting purpose. Lower levels of even, ambient illumination are provided throughout the space with local task lights providing greater illuminance at the task.
- b. Voltages of luminaires in renovated space shall match the base building lighting voltage and reuse existing circuits where applicable.
- c. With the popularity of LED in the market, designer tends to use 120V LED light fixtures to replace the existing 347V lighting circuit in the renovation project. However, this results in shifting the lighting load to our 600V/120V transformers originally designated for receptacle power. To prevent this, new LED luminaires in renovated areas shall NOT be sourced from 120V/208V panels except for specialized lighting (where 347V driver is not available) or in situation approved by the University.
- d. All serviceable and replaceable components (e.g. lamps, ballast, drivers) for luminaires shall not be blocked or impeded for access. Clearance acceptable to Facilities operation or access opening shall be provided. Clarify with U of C if in doubt prior to design and installation.
- e. For luminaires installed in staircases, fixtures shall not be mounted higher than 3000mm (10 feet) above finished floor where typical ladder can reach. Wall mounting is preferred.

3. Qualifications of the Lighting Practitioner

- a. Lighting design shall be performed or supervised by a practitioner credentialed as Lighting Certified (LC) by the National Council on Qualifications for the Lighting Professions (NCQLP).

4. Illumination Levels

- a. Required illumination level ranges for typical interior spaces are indicated in the following table. These ranges of illumination require the average illumination at the task (work plane) to be greater than the minimum value and less than the maximum value. For those areas not listed in the table, the IES Lighting Handbook may be used as a guide. The design illumination levels shall be confirmed by computer simulation for each of the typical space types throughout the building.

Lighting Requirements by Space Type		
Area / Activity	Required Illumination Level Lux (lumens/m ²)	Maximum Lighting* Power Density (W/m ²)
Office	450 – 600	11.9
Conference Meeting / Multipurpose Room	275 – 425	13.2
Classroom / Lecture / Trainings	450 – 600	13.3
Lobby	175 – 275	9.7
Atrium	175 – 275	0.1/m (height)
Lounge / Recreation	275 – 425	9.4
Dining Area	175 – 275	7.0
Food Preparation	450 – 600	10.7
Washrooms	175 – 275	10.5
Corridor / Transition	175 – 275	7.1(>2.4m side); 8.4(<2.4mwide)
Stairs	175 – 275	7.4
Storage	175 – 275	6.8
Electrical / Mechanical / Telecommunication Rooms	175 – 275	13.4

*duplicated from 5.17.3

5. Visual Comfort

- a. The lighting system must be designed to reduce glare, minimize contrast ratios, and provide proper color rendering as recommended in the latest issue of the Illuminating Engineering Society of North America (IES) Lighting Handbook.

6. Energy Efficient Design

- a. At a minimum, lighting design must comply with the current version of ASHRAE/IES Standard 90.1 maximum lighting power densities. The table above lists the requirements for typical interior spaces; the Standard shall be consulted for other space types. Task lighting is included in the maximum LPDs provided by the Standard.

7. Accessibility for Servicing

- a. Careful consideration must be taken in the design of lighting systems regarding servicing of the fixtures and replacement of lamps and ballasts. This issue needs to be discussed with building operation staff to determine the dimensional limits of servicing equipment.

8. Luminaires

- a. All luminaires must be appropriately selected based upon the expected application.
- b. Luminaires shall be recessed, pendant, or surface mounted. Indirect/direct fixtures shall have a minimum 2% indirect component and 50% direct (maximum) component. Fixtures must have a minimum efficiency of 65%.



- c. Where parabolic fixtures are used, louvers shall be semi-specular or diffuse finishes; specular finishes shall not be used.
- d. All recessed downlights must use LED. No incandescent or HID technology shall be used
- e. Many fixtures have different lamp and driver options. For ease of maintenance, all similar building luminaires shall use the same lamps LED and drivers. All these components are to be readily accessible.

9. Lamps

- a. Effort shall be made to minimize the number of lamp types within a facility to simplify lamp maintenance. LED shall be used, CFL, incandescents, HID are no longer allowed.
- b. In retrofit applications of LED, all fluorescent lighting lamps and ballasts must be disposed of through specialized disposal firms that destroy the PCBs and recover the mercury that is contained in the lamps.

10. LED (Light Emitting Diode) Luminaire

- a. Supplier of LED luminaire shall demonstrate experience of designing, manufacturing and implementing LED luminaires by providing:
 - i. Information on a minimum of 3 other projects of similar scope
 - ii. List and contact information of any other customers who have used the same or proposed fixtures.
 - iii. Description of the manufacturer indicating the number of years in business and the number of years of in LED manufacturing.
 - iv. Facility that manufactures the LED luminaires shall preferably be ISO 9001 certified, indicating quality management systems.
- b. LED lamps shall be capable of +50,000 operating hours. The luminaire should be able to operate 50,000 hours before the LEDs reach their end of life (L70) i.e. 70% of initial lumen output, net of any LDD. The Minimum luminaire efficacy be tested and certified using the latest IES Standards LM-79 with 70 lumens/watt., CRI 80. Bidder shall submit analysis and diagrams derived from professional lighting software (e.g. AGi32 v.3.2, Visual Professional) that provides detailed confirmation that the proposed luminaire meets IES RP-8. The fixture shall be ROHS compliant and contain no Lead, Cadmium or Mercury.
- c. They shall also meet one or more of the following standards: CSA, UL
 - i. Underwriters Laboratories, Inc. (UL)
 - o 1310 and 8750 – Light Emitting Diode (LED) equipment for use in lighting products.
 - ii. International Electrotechnical Commission (IEC):
 - o IEC 61347-1 – General and safety requirements for lamp control gear IEC 61347-2-13 – Particular requirements for electronic control gear for LED modules
 - o IEC 62384 b- DC or AC supplied electronic control gear for LED modules –



- performance requirements
 - IEC 61000-3-2 - Harmonic current emissions
 - IEC 61547 - EMC immunity requirements
- iii. Federal Communications Commission (FCC)
 - Part 15 Class B: Radio Frequency Devices. Commercial rated.
- iv. Institute for Electrical and Electronics Engineers (IEEE)
 - IEEE PAR1789 - Recommending practices for modulating current in High Brightness LEDs for mitigating health risks to viewers
- d. Acceptable LED Manufacturers:
 - i. Lutron
 - ii. Philips
 - iii. Osram
 - iv. GE
 - v. Sylvania

Recognized by UL for use in the US and Canada. Provide evidence of compliance upon request.

Alternate manufacturer with minimum 3 years experiences in manufacture of dimmable electronic lighting drivers may be considered at the discretion of the University.

- e. Recommended recessed LED luminaire fixtures. (*adopted by the university projects):
 - i. Elite Application (for aesthetic) – indirect optics
 - Metalux – Encounter Series
 - Corelite – DIVIDE DRI Series
 - Focal Point – Equation 2\Luna Series
 - Philips – Versform
 - Visioneering – LRTF Series, BEVEL Series
 - ii. General Purpose (for functional) - direct optics
 - Lithonia – 2 BLT Series or similar
 - Focal Point – Amica Series or similar
 - Metalux 24GR LED
 - Visioneering LTRA Series

Consideration shall be given if 347V is available when required to match base building lighting in project.

- f. Modularity: Luminaires should be designed for ease of component replacement, including LED engines/modules, drivers, surge devices and they should accommodate end-of-life disassembly.



- g. Electrical Immunity: Luminaire shall contain a separate surge protection device (SPD) compliant with ANSI/IEEE Surge Voltages in Low Voltage AC Power Circuits, C62.41.2-2002.
- h. Operating temperature: Luminaire shall be capable to operate between -30° to $+40^{\circ}$. Temperature operating range applies to all electrical components in the luminaire, including LED engine/modules, drivers, and surge devices.
- i. LED dimming: LED dimming shall be equal in range and quality to a commercial grade incandescent dimmer. Quality of dimming to be defined by dimming range, freedom from perceived flicker or visible stroboscopic flicker, smooth and continuous change in level (no visible steps in transitions), natural square law response to control input, and stable when input voltage conditions fluctuate over what is typically experience in a commercial environment. Demonstration of this compliance to dimming performance will be necessary for substitutions or prior approval.
- j. LED dimming control Input:
 - i. 4-Wire (0-10V DC Voltage Controlled) Dimming Drivers
 - o Must meet IEC 60929 Annex E for General White Lighting LED drivers
 - o Connect to devices compatible with 0 to 10V Analog Control Protocol, Class 2, capable of sinking 0.6 ma per driver at a low end of 0.3V. Limit the number of drivers on each 0-10V control output based on voltage drop and control capacity.
 - o Must meet ESTA E1.3 for RGBW LED drivers
 - ii. Digital (DALI Low Voltage Controlled) Dimming Drivers
 - o Must meet IEC 62386
 - iii. Digital Multiplex (DMX Low Voltage Controlled) Dimming Drivers
 - o Must meet DMX / RDM: USITT DMX512A and ANSI E1.20 (Explore & Address)
 - o Capable of signal interpolation and smoothing of color and intensity transitions
- k. LED Drivers
 - i. Driver must limit inrush current.
 - ii. Drivers shall have dimming capability from 5% and 1% as specified to suit the project and user requirement.
 - iii. Power supplies shall be capable of operation at 60Hz with a power factor of 90% or better. The driver and its components shall operate normally for input voltage of 120V through 277V AC with fluctuations of $\pm 10\%$.
 - iv. Withstand up to a 1,000 volt surge without impairment of performance as defined by ANSI C62.41 Category A.
 - v. No visible change in light output with a variation of plus/minus 10 percent line voltage input.
 - vi. Total Harmonic Distortion less than 20% percent and meet ANSI C82.11

maximum allowable THD requirements at full output. THD shall at no point in the dimming curve, allow imbalance current to exceed full output THD.

- vii. Driver must support automatic adaptation, allowing for future luminaire upgrades and enhancements and deliver improved performance:
- viii. Adjustment of forward LED voltage, supporting 3V through 55V.
- ix. Adjustment of LED current from 150mA to 1.4A at the 100 percent control input point in increments of 1mA. LED drive current should be equal to or less than 50% of the maximum LED chip design. Using high drive currents to reduce the number and cost of LED devices are not acceptable.
- x. Adjustment for operating hours to maintain constant lumens (within 5 percent) over the 50,000 hour design life of the system, and deliver up to 20 percent energy savings early in the life cycle.
- xi. Driver must be capable of configuring a linear or logarithmic dimming curve, allowing fine grained resolution at low light levels
- xii. LED dimming driver shall provide continuous step-free, flicker free dimming similar to incandescent source

I. Installation

- i. To be installed per manufacturers prescribed methods.
- ii. Driver may be remote mounted up to 300 ft. (100 m) depending on power level and wire gauge.
- iii. 0-10V input shall be protected from line voltage miswired, and shall be immune and output unresponsive to induced AC voltage on the control leads.
- iv. Do not install equipment until following conditions can be maintained in spaces to receive equipment:
 - o Ambient temperature: -30 degrees to 40 degrees C.
 - o Relative humidity: Maximum 90 percent, non-condensing.
 - o Protected from dust and excess moisture during installation.

m. Warranty

- i. Provide manufacturer's warranty (include on-site replacement, transportation, installation, removal and labor cost) covering 3 years on drivers, 5 years on LED module (failed light output from more than 10% of the individual LED sources constitutes luminaire failure) from date of purchase.
- ii. Luminaire manufacture to operate driver at or below the required driver warranty temperature. Luminaire manufacturers failing to operate the driver, at the project required ambient temperature; within the driver manufacturer warranty parameters will be responsible for all driver warranty related costs over the warranty period.

11. Ballasts (only apply to existing ballast retrofit)

- a. Ballasts for linear and compact fluorescent lamps shall be electronic with a minimum power factor (PF) of 0.95 and a maximum total harmonic distortion (THD) of 20%.



- b. When applicable, programmed start ballasts shall be specified for use in linear fixtures that are frequently switched on/off, such as with occupancy controls.
- c. Electronic ballasts shall have a sound rating of “A” for 430 mA lamps, “B” for 800 mA lamps and “C” for 1500 mA lamps. Ballast shall operate as a parallel circuit, allowing remaining lamp(s) to maintain full light output if one or more lamp fail. Special consideration shall be given to the ballast types where an electronic clock system is also specified to confirm compatibility of application.
- d. Each fluorescent luminaire installed on branch circuits with voltages exceeding 150 volts-to-ground shall be provided with a disconnecting means integral with the luminaire that simultaneously opens all circuit conductors between the branch circuit conductors and the conductors supplying the ballast(s) and marked in a conspicuous, legible, and permanent manner adjacent to the disconnecting means, identifying the specific purpose. When retrofitting existing luminaires, recertification must be done by an accredited testing agency. A label must be applied inside the luminaire indicating the company, ballast\driver type, lamp type and number of lamps controlled, voltage of ballast\driver, number of lamps and lamp type and date of install.

12. Circuiting and Switching

- a. Lighting circuits shall be designed based on a realistic and adequate zoning analysis. The zoning analysis must account for separate lighting control strategies, unique occupancy areas, and maintain lighting zones smaller than 100 m² or one bay. Proper zoning allows for better control of lighting, especially during after-hours operation, while proper circuiting can minimize the complexity and cost of the lighting control system.

13. Lighting Controls

- a. Manual, automatic, or programmable microprocessor lighting controls shall be provided for all lighting, with the exception of exit sign branch circuitry and life safety egress lighting defined by the Alberta Building Code. The application of these controls and the controlled zones depend on a number of space factors such as: space type, frequency of use, available daylighting, and typical schedule.
- b. Lighting controls range from simple line voltage automated switches to complex low-voltage lighting control panels depending on size and scope of project. Lighting control systems typically include standard or astronomical time clocks, occupancy sensors, photosensors (light level), and override switches, but can include a myriad of options such as ID card readers and individual PC-based lighting controls. The following control strategies shall be adopted:
 - i. Individual space control in building without central system – wall or ceiling mounted vacancy sensor/power packs. In general, individual office and classroom lighting shall be “manual on, sensor off”. (Note: Usually is only achievable via low voltage power pack. Occupancy sensor can provide automatic on/off only)

Acceptable manufacturer:

Low voltage :

- a. Acuity nPODM series; nCM-PDT-9 & 10 series;



b. Cooper Wavlinx CAT Lighting Controls.

Line voltage : Lutron, Leviton, Hubbell

- ii. Renovated space\extension in building where central control system exists (e.g. Douglas relay/Encillium) – reuse, modify or add new component to suit existing system.
- iii. New building\construction – design and product to be reviewed and approved by U of C Facilities – Campus Engineering. Central processor smart lighting control for public circulation space and similar areas shall be avoided.(If a PC-based lighting control is required, an open protocol networking system via ethernet cables shall be used. Proprietary cable bus is not acceptable

c. For new construction\new wall, all lighting control wiring shall be installed in conduit.

14. Time Clocks

- a. An on/off time schedule must be included in the control system for all lighting except security lighting and lighting in spaces where occupants could be in physical danger due to loss of light. This control system shall incorporate lighting sweeps, warning flashes, or other methods to ensure lighting is off in unoccupied spaces during scheduled unoccupied times. All on/off times must be listed on the time clock for inspection and testing. Time clock to be electronic type and come with battery back up to maintain programming.

15. Occupancy Controls

- a. Occupancy sensors shall be provided for the following space :
 - i.
 - ii. All pantry
 - iii. Restrooms (full height cubicle shall be provided with individual occupancy sensor)
 - iv. All storage and file rooms smaller than 60 m2.
 - v. Any other regularly unoccupied spaces not mentioned.
- b. Occupancy sensors shall be ultrasonic, or passive dual sensors based on the application. Each occupancy sensor shall have a manual override and shall control no more than one enclosed space, though some applications may require multiple occupancy sensors to adequately control a single space. Each occupancy sensor shall be marked by a label identifying the panel and circuit number.
- c. No occupancy controls shall be used in mechanical or electrical rooms or other spaces where occupants could be in physical danger due to loss of light. All low voltage and line voltage wiring to be installed in conduit. No free air cabling allowed.

16. Dimmers (0-10V dimming, class 2) [other than central system] Acceptable manufacturer:

- a. Acuity: PODM-SA-D –WH (dimmer); PP20 (power pack) 120 or 347V; WV PDT 16 (wall sensor); CM PDT (ceiling sensor).



- b. nLight Product: nPODMA-DX (dimmer); nPP16-EFP or ER/EFP (power pack); nCM PDT (motion sensor)
- c. Lutron: DIVA C.L dimmer DVTV; PP-DV-M (Manual on power pack) or PP-347H ; LOS-WDT series (wall sensor).

(Note: DIVA “DVSTV” 0-10V dimmer that does not support power pack should not be used in area where vacancy/occupancy sensor is required.)

17. Photo Controls

- a. Photosensors are typically used to either control dimming ballasts for lumen maintenance or reduce lighting levels in response to available daylighting. Photo sensors shall be provided for the following space and occupancy types:
 - i. All regularly occupied perimeter spaces.
 - ii. All other spaces that are anticipated to provide daylight that will displace the installed lighting by at least 1,000 full load hours per year.
 - iii. In addition, integrated photo/occupancy sensors shall be provided for perimeter offices smaller than 10 m².
 - iv. Photo control system shall reduce the electric lighting by simple on/off, stepped dimming, or full dimming controls. Control strategy can be either open-loop or closed loop, but needs to be programmed to minimize lamp cycling and occupant distraction.

18. Override Controls

- a. An easily accessible local means of temporary override must be provided in all spaces to continue operations per the Alberta Building Code or local energy code. This override is typically embedded in a space located timer switch, but PC-based and other override strategies are acceptable. However, overrides must be automatic; phone systems that depend on facility managers to control the local lighting are not allowed.
- b. Where PC-based (e.g. ENCELIUM lighting system) is adopted in a building, a hand-operated master override switch located on ground floor electrical room shall be provided, which turns on all lights of the building. This could enable the building operator to find out which light has failed.

19. Exit Signs

- a. For renovation in existing building with red exit sign, application of “Pictogram” green exit sign shall observe latest Standata, and City’s Bulletin directives for proper application. Consultant should clarify with AHJ prior to tender drawing if in doubt, so a suitable type of exit sign be used. U of C prefers thermoplastic products:
 - i. Red Exit Sign
 - o Lumacell GRANDE Series or Ready-Lite Ultima Series
 - ii. Green Exit Sign (pictogram)
 - o Lumacell CMPS – L Series (AC)



- Ready-Lite CMPS-RL Series (AC)
- AimLite RPNP-U-WHT-UNVCD

(Note: edge-lit product applies where required to match architectural design)

- b. Exit signs shall NOT be “self-powered”. There shall not be built in battery inside the exit sign, and thus no remote heads attached. All exit sign specified shall be 120/347V AC connected to building emergency/generator backup source unless otherwise agreed and approved by U of C Campus Engineering.

20. Emergency Lighting

- a. Battery Packs will not be allowed in any buildings that are supported by an emergency generator except in areas listed in item d. below
- b. Emergency lighting shall be provided in accordance with the requirements of the Alberta Building Code. At a minimum, unswitched emergency lighting shall be provided in the following areas (Contactors that are installed for the switching to emergency lighting in theatres and classrooms that are used for egress are to be located at a reasonable working height or if above ceilings to be in an area that is readily accessible with the use of a step ladder and on a flat and level surface. Not to be located above seating or tiered or sloped floors).
 - i. Lighting in zones covered by CCTV cameras
 - ii. Security zones
 - iii. Stairways
 - iv. Exit signs
 - v. Egress corridors
 - vi. UPS and battery rooms
- c. Emergency lighting may be switched in the following areas:
 - i. Communication equipment rooms
 - ii. Electrical rooms
 - iii. Mechanical rooms
 - iv. Fire command centres
 - v. Security control centres
 - vi. Technology/server rooms
 - vii. Building exits (switched by photocell)
- d. Supplemental battery powered emergency lighting is also required recommended in the following spaces to bridge the generator start-up time:
 - i. Generator rooms

- ii. Automatic Transfer Switch (ATS) rooms for buildings where the ATS is not located in the generator room

21. Mechanical and Electrical Spaces

- a. Lighting in equipment rooms or service rooms shall be provided by industrial-type fluorescent fixtures. Care shall be taken to locate light fixtures so that lighting is not obstructed by tall or suspended pieces of equipment. Physical protection such as wireguards or fixture location shall be provided for light fixtures to prevent lamp/fixture damage. Emergency lighting shall also be installed in these rooms.

22. High Bay Lighting

- a. Lighting in shop, supply, or warehouse areas with ceiling above 5.0m shall be LED luminaires. Conventional metal halide fixtures and high pressure sodium lamps for high bay application are no longer used.

23. Conference Rooms and Training Rooms

- a. These spaces shall have a combination of lighting options to provide multiple scenes for space flexibility. Typical scenes would be table illumination for facial rendering at meetings, higher light at the front for speakers' illumination, and lower light at front for media presentations.

24. Other Special Areas

- a. Special lighting design concepts are encouraged in these spaces. The lighting design shall be an integral part of the architecture. Consideration must be taken by the certified lighting designer to integrate the design with the interior finishes and furniture arrangement to enhance the functionality of the spaces. Further consideration must be taken to adhere to the energy criteria, maintenance criteria, as well as minimizing the number of special lamp types and fixtures required. Areas generally requiring special lighting treatment are as follows:

- i. Main Entrance Lobbies
- ii. Atriums
- iii. Elevator Lobbies
- iv. Public Corridors
- v. Public Areas
- vi. Auditoriums
- vii. Conference Rooms
- viii. Training Rooms
- ix. Dining Areas and Serveries
- x. Libraries

25. Exterior Lighting Design Criteria



- a. Exterior lighting systems shall comply with all the requirements of section 5.3.3 of ANSI/ASHRAE/USGBC/IES Standard 189.1-2011.
- b. Exterior luminaires must comply with all local zoning laws and lighting levels for exterior spaces must be as indicated by table in 25 a. below
- c. Lighting fixtures at all entrances and exits shall be connected to the emergency lighting system. Where security lighting is required and HID restrike time is not acceptable, UPS backup, HID capacitive/ride through circuitry or instant-on lamp sources may be required.
- d. All exterior lighting shall conform to BUG rating (or better) as identify in Sustainability requirement section per paragraph 5.17.1 .13.
- e. Conduit size run underground for street lighting shall be PVC, 1”C minimum.
- f. There shall be no cable splicing. Splice well will be considered and reviewed subject to approval of the University.
- g. Aluminum conductor and armor cable (tech cable) are not allowed. Minimum size of conductor shall be #10 AWG copper. Size shall be increased to account for voltage drop per code requirement.
- h. Street lighting control would be photocell or BMS (confirm with U of C). Do not use time clock.
- i. Each individual street\walkway luminaire shall have a fuse holder incorporated at the base of the lamp post which is assessable and could isolate the lamp without disturbing the circuit continuity to other light fixtures on the same circuit.

26. Parking, Roadway and Pathway Lighting

- a. Parking lots and roadway lighting shall be designed with high-efficiency, pole-mounted luminaires. Illumination ratios shall not exceed a 10 to 1 maximum to minimum ratio and a 4 to 1 average to minimum ratio.

Application	Normal Illumin(Lux)	Uniformity Avg/min
Sidewalks	25	4:1
Roadways	10	4:1
Major Roadways	15	4:1
Open Parking Lots	15	4:1

- b. The following LED luminaires, , must be used. Alternates on luminaire or lamp pole will not be accepted:

Application	Type	Mount Ht.	Catalogue #
Sidewalks	LED	12 feet	CREE ARE-EDR-2MP-R3-06-E-UH-BK-350-40K
Parking lot / Roadway	LED	25 feet	CREE GWY-M-A-13L-40K7-2M-UH-BK or LUMEC RPM-90W60LED-840-G1-R2M-



			HVU-BK
Bollard	LED	-3 feet	CREE OSQP-C-3L-30K7-2R-34-P4-BK or GARDCO PBL-36-14L-350-nw-g2-3-347
Building Exterior	LED	15 feet	CREE SEC-EDG-2 <u>MB</u> -WM-06-E- <u>UH</u> -BK- 350-40K or GARDCO PWS-P-A03-740-2-347-BK

- c. Note that the above catalogue numbers are based on Type II optical distribution and 347V power source. However, architectural features and landscaping may require alternative distribution. In this case, the catalogue numbers shall be changed to reflect appropriate optical distribution light output and voltage to suit the design.
- d. The following shows campus standard approved for light poles with applications:

Application	Manufacturer	Catalogue #	Specifications
Side walk	Ceco Poles & Structures	CE35R12	L = 12 feet x 3.5" round, black
Roadway single davit	Ceco Poles & Structures	CE258SD	L = 25 feet, Davit = 8 feet, black
Roadway double davit	Ceco Poles & Structures	CE258DD	L = 25 feet, Davit = 8 feet, black
Parking lot single davit	Ceco Poles & Structures	CE258SD	L = 25 feet, Davit = 8 feet, black
Parking lot double davit	Ceco Poles & Structures	CE258DD	L = 25 feet, Davit = 8 feet, black

27. Structured Parking

- a. Care must be taken in locating fixtures to conform to the traffic patterns and maintain the required vehicle clearance.

28. Exterior Wall and Security Lighting

- a. Wall mount exterior luminaire complete with mounting arms\bracket mounted. Luminaire mounted 15 feet above floor typically.

29. Exterior Lighting Controls

- a. Exterior lighting circuits shall be controlled by photocell and a time clock controller (not for street lighting), with an astronomical dial, to include both all-night and part-night lighting circuits. A minimum of 75% of the architectural, site, and parking lighting shall be switched off three hours after the building is typically unoccupied or 23:00, whichever is later.

5.17.9 Voice and Data Distribution System

1. Refer to Voice and Data Distribution design standard 5.18 for detail UCIT requirements.
2. Install all data cabling 'continuously' in conduit. All conduits shall terminate to new or base building cable tray with grounding bushings. If cable trays are not present in project, run

directly to communication room/rack. Bond cable trays and its bonding conductor to data room ground bar. Bond all communication racks to ground bar in data room.

3. A copper ground bar terminal (250mmX50mmX6mm) with standoff shall be provided in data or communication room. Locate ground bar in accessible location, preferably at high level.
4. Minimum size for individual drop of conduit is 25mm (1")

5.17.10 Emergency Power Systems

1. Emergency Power Systems

- a. Must be designed to comply with the requirements of the Alberta Building Code and the following standards. Unless otherwise specifically authorized by the U of C representative, all facilities shall be provided with a standby generator to supply power to the facility in the event of a sudden loss of power.
 - i. Canadian electrical code and provincial and local amendments
 - ii. Provincial building code
 - iii. Local building code
 - iv. NEMA motor and generator standards
 - v. CSA Standard 282 – Emergency Electrical Power Supply in Buildings
 - vi. ANSI/API 650-1988 Welded Steel Tanks for Oil Storage
 - vii. ANSI/NEMA MG1-1978 Motors and Generators
 - viii. CAN/CGSB 3.6-M90 Automotive Diesel Fuel
 - ix. ISO 3046/1-1981 Performance Specification for Reciprocating Internal combustion engines
 - x. CAN4-S601-M84 Steel, Above-Ground Horizontal Tanks for Flammable and combustible Liquids

2. Generator Systems

- a. The system shall consist of a central engine generator and a separate distribution system with automatic transfer switch(es), distribution panels, and 600/347V lighting panel (if applicable) with dry-type transformers feeding 208/120V panels as required. Effort must be made to ensure proper coordination of mechanical engineering elements of the generator systems design.
- b. If the unit is to be installed outdoors, it shall be provided with a suitable walk-in acoustic enclosure and jacket water heaters to ensure reliable starting in cold weather.
- c. The unit must be derated in accordance with manufacturers' recommendations as required for the U of C location and climate conditions. Operation of starting batteries and battery chargers must also be considered in sizing calculations. In humid locations heaters can reduce moisture collection in the generator windings. Critical silencers are required for all generators. Acoustical treatment of the generator room shall be provided if



necessary. Temperature and ventilation shall be maintained within the manufacturer's recommendations to assure proper operation of the unit. Calculations to support the size of the intake air supply for combustion, cooling and radiation as well as exhaust piping, and exhaust paths shall be provided by the design engineer.

- d. Radiators shall be unit-mounted if possible. If ventilation is restricted in indoor applications, remote installation is acceptable. Heat recovery and load shedding shall not be considered. Remote location of radiators shall be designed to avoid excess pressure on the piping seals.
- e. The engine generator shall be sized to serve approximately 110 percent of design load; ideally it shall run at 60 percent to 80 percent of its rated capacity after the effect of the inrush current declines. When sizing the generator, consider the inrush current of the motors that are automatically started simultaneously. The initial voltage drop on generator output due to starting currents of loads must not exceed 15 percent. Day tanks shall be sized for a minimum capacity of four hours of generator operation. Provide direct fuel oil supply and fuel oil return piping to the on-site storage tank. Piping shall not be connected into the boiler transfer fuel oil delivery "loop".
- f. Emergency power shall be provided for the following "Fire and Life-safety" functions:
 - i. Emergency lighting as defined in 5.17.8.18 & 19
 - ii. Fire alarm system
 - iii. Generator auxiliaries
 - iv. Fire pump
 - v. Telephone\Communication switch
 - vi. Security systems (except if system built-in battery is present)
 - vii. Mechanical control systems
 - viii. Elevators (one per bank)
 - ix. Smoke control systems
 - x. High Rise Stairway Pressurization Fans
 - xi. Supply fans in order to maintain building pressurization.
 - xii. Other associated equipment designated by code
- g. Apart from the above, emergency power shall also be provided as "back-up" sources for the following "non-life safety" systems to minimize damages to the university:
 - i. Uninterruptible power systems serving technology/server rooms
 - ii. Air conditioning systems for technology/server and UPS rooms
 - iii. Exhaust fan in UPS battery rooms
 - iv. Back up lighting to accommodate extended power outage (project dependent)



- v. Air conditioning systems for communications rooms
 - vi. Laboratory fume hoods (50% minimum flow rate)
 - vii. Laboratory fridges and/or freezers where required by users.
 - viii. Heating pumps
 - ix. Boilers
 - x. BMS system
 - xi. Fume hood exhaust fans.
 - xii. Air Handlers fans
 - xiii. Sewage ejector pumps
 - xiv. sump pumps
 - xv. Other equipment as considered necessary to prevent the building from freezing.
- h. Fire and Life Safety and Backup systems shall be connected to separated emergency power arrangement as per code requirement or as commented by the Authority Having Jurisdiction.
- i. Generator set to include automatic shut down and alarm indication for:
- i. Low oil pressure
 - ii. High coolant temperature
 - iii. Overspeed
 - iv. Overcrank
 - v. High engine temperature
 - vi. Short circuit
 - vii. Alternator overtemperature
 - viii. Emergency stop (on exterior of enclosure)
- j. Generator set to include warning systems and indication for:
- i. Low oil pressure
 - ii. Low coolant temperature
 - iii. Day tank fuel leak detection
 - iv. Low battery voltage
 - v. Generator output breaker open
 - vi. Selector switch “not in automatic” or “off” position
 - vii. Coolant temperature rising



- viii. Visual indicator of fuel level in tank
 - ix. Visual indicator of coolant level in radiator
 - k. Generator alarms must be provided in the generator room. All malfunctions shall be transmitted to the BAS.
 - l. Automatic transfer switches serving motor loads shall have in-phase monitor (transfer when normal and emergency voltages are in phase) to reduce possible motor damage caused by out-of-phase transfer. Life safety equipment shall have its own transfer switch and distribution.
 - m. Automatic transfer switches shall include a bypass isolation switch that allows manual bypass of the normal or emergency source to insure continued power to emergency circuits in the event of a switch failure or required maintenance.
 - n. See Mechanical Design Guidelines section for information on fuel oil piping and underground fuel oil tanks. These tanks are not to be mounted underground.
 - o. Generators shall be located at least 30 m from communications frame equipment to avoid radio frequency interference. Generator and generator control panel shall be located in a separate room or enclosure. The environmental systems shall meet the requirements of the Alberta Building Code, CAN/CSA-C282 Standards for Emergency Electrical Power Supply for Buildings, and meet the combustion air requirements of the equipment. Rooms must be ventilated sufficiently to remove heat gain from equipment operation. The supply and exhaust louvers shall be located to prevent short circuiting. Generator exhaust shall be carried up to roof level (U of C preference) in a flue or exhausted by way of compliance with the generator manufacturer's installation guidelines. Horizontal exhaust through the building wall shall be avoided.
 - p. For the diesel engine driven generator set, the standard 12 month warranty period prescribed shall be extended to the lesser of 60 months from date of final acceptance or 1500 in service operating hours.
 - q. The designer must clearly indicate in the tender document that in the event of an emergency failure during the warranty period of any product(s), material(s) or system(s) installed under the Emergency Power Systems, and the issuer of the warranty is unable or chooses not to respond to a request by the University of Calgary for immediate emergency repair/replacement of the affected product, material or system, then the University of Calgary reserves the right to recover, from the issuer of the warranty, all costs incurred by the University or University engaged forces in affecting the immediate repair/replacement.
3. Shop Drawings
- a. Submit completed shop drawings for review and approval before commencing project
 - b. Incomplete shop drawing submissions will be returned without review.
 - c. Only shop drawings for specific equipment being supplied will be accepted. Generic or catalogue data is not acceptable.
 - d. Shop drawings to include:



- i. Schematic power and control diagrams showing generator, voltage regulator, metering, battery, battery charger, governor, and all engine generator protection and controls. Indicate all field connection requirements.
- ii. Make and model of engine, generator, governor, voltage regulator, battery charger, battery, exhaust silencer, block heater/thermostat, vibration isolators, control devices and power components; complete with technical and performance data.
- iii. Confirmation that the generator set will comply with 100% shop load performance requirement.
- iv. Dimensioned drawings for alternator, engine, control panel, sound- attenuated enclosure, exhaust silencer access requirements and accessories.
- v. Indication of all anchoring/mounting locations, and all power/control connection locations.
- vi. Fuel day tank storage and delivery system; flow rating, flow diagrams and other relevant data.
- vii. Automatic generator enclosure ventilation system including dampers, motorized operators and other related system components.
- viii. Confirmation that required engine power at 110% rated load condition, 0.8 pf, does not exceed the engine manufacturer's recommended standby power rating.
- ix. Manufacturer's published standby power output curves and fuel consumption curves.
- x. Description of generator set operation, including:
 - Automatic starting, including time in seconds from start of cranking until unit reaches rated voltage and frequency.
 - Automatic shutdown and alarm on the following:
 - Over cranking
 - Over speed
 - High engine temperature
 - Low lube oil pressure
 - Short circuit
 - Alternator overvoltage
 - Lube oil high temperature
 - Low coolant shutdown
 - Over temperature on alternator
 - Manual remote emergency stop

4. Operation and Maintenance Data

- a. Provide four copies of operation and maintenance manuals for the diesel generator set.



- b. Provide an electronic copy of manuals in pdf form.
- c. Include in operation and maintenance manual instructions for the specific unit supplied. General manufacturer descriptions are not acceptable. Also operation and maintenance instructions for engine, alternator control panel, automatic transfer switch, manual bypass switch, battery charger, battery, fuel system, generator room/enclosure ventilation system, exhaust system and accessories to enable effective operation, maintenance and repairs when required.
- d. Technical data:
 - i. Illustrated parts list with parts catalogue numbers.
 - ii. Schematic diagrams of electrical controls.
 - iii. Flow diagrams for:
 - o Fuel system.
 - o Lubricating system.
 - o Cooling system.
 - o Certified copy of all factory test results.
 - o Precise details for adjustment and setting of time delay relays or sensing controls which require on-site adjustment.
 - o Complete engine tear-down manual.
 - o Copy of factory warranty.
 - o Complete set of as-built physical, schematic and wiring diagrams, as well as all installation instructions

5. Maintenance Materials

- a. Provide required maintenance materials, special tools and spare parts. Items to include:
 - i. 2 sets fuel filter replacements.
 - ii. 2 sets lube oil filter replacements.
 - iii. 2 air cleaner filter elements.
 - iv. 4 complete sets control panel fuses.
 - v. 4 of each type of indicating lamp.
 - vi. 1 complete set of fan belts.
 - vii. 1 set routine service tools, including required special tools.
 - viii. Replacement engine block heater.

6. Source Quality Control

- a. Factory test generator set including engine, alternator, control panels, transfer switch and accessories in presence of consultant.



- b. The generator set and accessories are to be manufactured and tested in accordance with the manufacturer's quality assurance program. The program shall comply with the intent of CSA CAN3-Z299.3 or ISO 9001. Provide a copy of the manufacturer's quality assurance procedures manual if requested by consultant.
- c. Test procedures:
 - i. Prepare blank forms and check sheet with spaces to record data. At top of first sheet, record:
 - o Date and location.
 - o Generator set serial number.
 - o Engine make, model, serial number.
 - o Alternator make, model, serial number.
 - o Voltage regulator make and model.
 - o Rating of generator set – KW, KVA, volts, amps, RPM, Hz.
 - ii. Mark check sheet and record data on forms as test proceeds.
 - iii. Provide test result forms in duplicate at end of testing.
 - iv. Provide reactive type load bank and related controls to allow testing including 100% step loads. Provide all necessary instrumentation and recording equipment.
 - v. Provide consultant/engineer signature on all completed test forms to indicate concurrence on test results.
 - vi. Name of test operator is to be clearly indicated on all test forms.
- d. Tests required:
 - i. Perform functional and load tests to verify conformance with specifications, codes and performance requirements.
 - ii. Tests are to include the following:
 - o Automatic shutdown devices and trouble alarms. Tests to include actual out-of-limits operation with protective devices installed and in their in-service condition to prove sensor operation within manufacturers recommended limits. Jumper testing of sensors or remote simulation testing to prove shut downs is not acceptable.
 - o Automatic start-up, transfer to load, transfer back to normal building power, cool down, and shut down of engine.

7. Warranty

- a. For a diesel engine-driven generator set, the standard manufacturer's warranty period is required to be extended to 60 months or 1500 operating hours, whichever occurs first.

8. Delivery

- a. Store generator set and accessories in an indoor, dry, heated location until delivered to



site.

- b. Coordinate delivery so that equipment is delivered into an indoor, secure location.
- c. Coordinate handling, lifting and placement of generator set and all related system equipment.

9. Products

Diesel engine

- a. Turbo-charged, after-cooled, synchronous speed of 1800 rpm.
- b. Capacity: KW/KVA standby ratings as ordered.
- c. Rated continuous power in KW at rated speed, after adjustment for system losses in auxiliary equipment necessary for engine operation, is to be calculated as follows:

$$\text{Rated continuous output} = \text{Generator kW} \times \text{Generator Efficiency} @ \text{FL}$$

- d. Operation under the following site conditions:
 - i. Altitude 1100 m
 - ii. Ambient temperature 30C
 - iii. Engine overload capability 100% of continuous output.
- e. Cooling System:
 - i. Radiator: Heavy-duty industrial radiator mounted on the generator set base, or within the generator enclosure. A direct- drive electric fan, or unit-mounted, belt-driven fan for cooling to be provided as per direction of University of Calgary. .
 - ii. Coolant to be extended-life ethylene glycol antifreeze, non-sludging above -46C.
 - iii. Cooling system capacity to be sufficient to maintain manufacturers recommended engine operating temperature at 10% continuous overload at 40C ambient temperature.
 - iv. Radiator to be supplied with clear sight gauge to allow monitoring of coolant level.
 - v. Engine standby temperature to be maintained by a thermostatically controlled circulating block heater, minimum 3500W. Engine is required to start in ambient temperature of -35C, and take full-load transfer within 30 seconds.
- f. Provide a cooling system for fuel in external tanks to cool fuel during periods of low loading.
- g. Where required by the University of Calgary, provide a remote engine cooling radiator unit, complete with isolation valves to permit repair without need to drain radiator and piping. Include high pressure radiator cap and check valves on outgoing line. All remote radiators to be enclosed in lockable security cage.
- h. Engine Fuel:



- i. Generator set engine to use No. 2 diesel fuel, per CGSB-3-GP-6C.
 - ii. Fuel tank to be re-filled after site load test and commissioning operations.
- i. Engine Fuel System:
- i. Direct injection, mechanical fuel transfer pump, fuel filters and air cleaner, with fuel rack solenoid to be energized while the engine is running.
- j. Governor:
- i. Electronic actuator, speed droop externally adjustable from isochronous to 5%, temperature-compensated with steady - state speed maintenance capability of +/- 0.25%.
 - ii. Steady-state speed band of +/- 0.5%.
 - iii. Speed regulation, no-load to full-load, 5% maximum.
- k. Lubrication System:
- i. Lube oil filter to be replaceable, full-flow type, removable without disconnecting piping.
 - ii. Pressure lubricated by engine-driven pump.
 - iii. Lube oil cooler.
 - iv. Engine sump drain valve.
 - v. Oil drain line mounted so as to be clear of generator set base, and complete with shut-off valve to facilitate oil changes.
- l. Starting System:
- i. Positive-shift, gear-engaging 24VDC starter.
 - ii. Crank limiter to provide 6 cranking periods of 10s duration, separated by 5s rest period.
 - iii. 24VDC storage/starting battery system, with lead acid batteries.
 - iv. Batteries with sufficient cranking capacity to turn engine over for one minute at - 35C ambient temperature.
 - v. Battery charger to be constant-voltage, solid-state, two stage, trickle charge at standby, to equalize charge after genset use. Voltage regulation to +/- 2% output for +/- 10% input. Charger to be equipped with DC voltmeter, DC ammeter, on/off switch. Minimum charger capacity to be 7 amp.
- m. Engine Instrument Panel:
- i. Vibration isolated.
 - ii. Equipped with:



- Lube oil pressure gauge.
 - Lube oil temperature gauge.
 - Coolant temperature gauge.
 - Tamper-proof running time meter.
 - Fuel pressure gauge.
- n. Safety Guards
 - i. Engine safety guards to protect maintenance personnel from hot/ moving parts. Guards located so that maintenance work can be performed without guard removal.
- o. Environmental Drip Tray:
 - i. Provide a metal, removable drip tray to catch engine fluid Drips allowing draining and cleaning.
- p. Alternator:
 - i. To ANSI/NEMA MGI specifications.
 - ii. Output rating: 3-phase, 600V, 4-wire, 60 hz.
 - iii. Output rated at 40C ambient temperature;
 - iv. 100% full load operation, continuous.
 - v. 110% full load operation for 1 hr.
 - vi. 150% full load operation for 1 min.
 - vii. Revolving field, brushless, single bearing.
 - viii. Drip-proof.
 - ix. Ammortisseur windings.
 - x. Synchronous type.
 - xi. Dynamically-balance rotor permanently aligned to engine by flexible disc coupling.
 - xii. Rotating, brushless exciter.
 - xiii. EEMAC class H windings.
 - xiv. Thermistors imbedded in stator windings and connected to alternator circuitry.
- q. Voltage Regulation
 - i. Regulator equivalency – Basler Model XR2002F.
 - ii. Solid-state, temperature compensating.
 - iii. 3-phase sensing, automatic voltage control.



- iv. Adjustable voltage and frequency stability.
 - v. Voltage regulation +/- 2% or rated output voltage from no-load to full- load.
 - vi. Voltage rheostat capable of +/- 5% adjustment at any load.
 - vii. Voltage regulator able to remove excitation within 10s of alternator fault, and able to operate parallel to local utility.
- r. Control Panel
- i. Totally-enclosed mounting, isolated from prime mover in paralleling switchgear.
 - ii. Audio/visual annunciation with NFPA 110 Level 1 capability.
 - iii. Programmable micro-processor with digital display.
- s. Alternator Instrumentation.
- i. Digital meters, solid-state circuitry with 2% accuracy, flush- mounted in panel.
 - o Voltmeter: AC, scale 0-1000V
 - o Ammeter: AC, scale 0-full load.
 - o Wattmeter: scale 0-full load.
 - o Frequency meter: scale 55-65 Hz.
 - o kWhr meter.
 - ii. Voltmeter selector switch integral, panel-mounted, labeled “Off-PhA-PhB-PhC, A-B LL, B-C LL, A-C LL”
 - iii. Ammeter selector switch integral, panel-mounted, designed to prevent opening of circuit currents, four-position labeled “OFF – PhA – PhB – PhC – Neutral”
- iv. Instrument Transformers:
- o Potential; dry-type rated for indoor use;
 - i. Ratio; 600 – 120.
 - ii. Rating; 600V, 60 Hz BIL 10kV.
 - o Current; dry-type rated for indoor use;
 - i. Ratio; 1500 – 5.
 - ii. Rating; 600V, 60Hz, BIL 10kV.
 - iii. Positive action, automatic short-circuiting device in secondary terminals.
- v. Controls:
- o Engine start button.
 - o Selector switch; Manual – Off – Auto



- Engine emergency stop button and provision for remote emergency stop button.
- t. Alternator Output Breaker
 - i. Circuit breaker to be bolt-on, molded- case, temperature-compensated for 40C ambient temperature, with solid-state LSIG trip unit.
 - ii. Provide separate breaker for facilities that require fire pump connection to emergency generator.
- u. Panel Mounted Operating Lights
 - i. Normal power indicator light.
 - ii. Emergency power indicator light.
 - iii. Green indicator lights for “Breaker On” and red indicator lights for “Breaker Off”
 - iv. Solid-state Alarm Indication Lights: to include 2 sets of manually- reset NO/NC contacts wired to terminal block for remote annunciation on the following;
 - Low fuel level.
 - Low battery voltage.
 - Ventilation failure – for units installed inside a building.
 - Low coolant temperature.
 - v. Solid-state Controller: used for automatic shutdown alarms and warning alarms, with 2 sets of manually reset NO/NC contacts wired to terminal block for remote annunciation on the following;
 - Engine over crank.
 - Engine over speed.
 - Engine high temperature.
 - Engine lube “low oil pressure”.
 - Short circuit.
 - AC overvoltage.
 - v. Control panel button for lamp test/fault reset.
 - w. Synchronization and load sharing capability.
 - x. Provision of communication ports for remote monitoring.

External Equipment

- a. Steel Mounting Base:
 - i. Complete generator set mounted on structural steel base of sufficient strength and rigidity to protect unit from stress and strain during transportation to site, installation, and normal operation.



- ii. Skid assembly fitted with vibration isolators, where necessary as indicated by the University of Calgary.
 - iii. Spring-type isolators with side snubbers, adjustable for leveling.
 - iv. Sound insulation pads to be mounted between isolators and concrete floor or mounting pad.
 - v. Steel skid base to be securely fastened to concrete floor (interior), or concrete mounting pad (exterior).
- b. Exhaust System:
- i. Heavy-duty, high critical sound attenuation, horizontally- mounted exhaust silencer with valved condensate drain, plugs and flanged couplings.
 - ii. Heavy-duty flexible stainless steel exhaust pipe with flanged couplings, as required by the University of Calgary.
- c. All fittings and accessories as required for installation including gravity closed rain cap.
- d. Expansion joints; stainless steel, corrugated, of suitable length to absorb both vertical and horizontal expansion.
- e. Fuel Day Tank System:
- i. Fuel storage tanks; to ANSI/API 650, ULC labeled to ULC S601 and CSA B139.
 - ii. Day tank; .1 Remote, floor-mounted (interior) or skid-mounted (exterior), double-walled to appropriate ULC standards, sized for 8 hour generator run time at full load.
 - iii. Manual fill inlet with over-fill protection.
 - iv. Factory-installed leak detection system.
 - v. All vent fittings to be engineered to appropriate size.
 - vi. Where and integral fuel transfer pump is required, minimum flow is to be 23 liters/min.
 - vii. Fuel cooling system: required for interior unit locations.
 - viii. To be of sufficient capacity to prevent temperature of day tank fuel supply exceeding 115C under maximum generator load running conditions.
- f. Finishes:
- i. All unit finishes to be applied in accordance with University Of Calgary project requirements.
 - ii. Alternator control enclosure; interior, exterior, engine and alternator to be painted to match.
 - iii. Exhaust hoods, inlet air hoods, all ducts and racks to be grey.

- iv. Provide 0.25 liters touch-up paint for all colors.
- g. Equipment Identification:
 - i. Provide equipment identification in accordance with University of Calgary project requirements, including panel schedules, numbering of transfer switches, and output breaker identification.
- h. Control panel:
 - i. Nameplates for all control panel switches.
 - ii. Nameplates for all meters, alarms, indicator lights and minor controls.
- i. Fabrication: Shop assembly or generator unit to include:
 - i. Skid base.
 - ii. Engine and radiator.
 - iii. Alternator.
 - iv. Control panel.
 - v. Starting batteries and battery charger.
 - vi. Automatic transfer equipment. (Separate Spec to cover ASCO transfer switch).
- j. Generator output breaker.
- k. External load test connection point
 - i. Include weatherproof splitter mounted in location determined onsite. This will be a permanent connection point to allow load to be connected for annual load tests.
 - ii. To be connected to first emergency power distribution point with suitable means of disconnect and protection.
 - iii. Size to be designed to connect 100% rated load banks.
- l. Approved Manufacturers and suppliers
 - i. Generator Set Manufacturers:
 - o Caterpillar Power Products (Finning Alberta)
 - o Cummins/Onan Power Systems (Cummins Alberta)
 - o MTU/Detroit Diesel/John Deere (Wajax Calgary)
 - o Kohler/Detroit Diesel/John Deere (Frontier Power Generation)
 - ii. Automatic Transfer Switches (Separate specification):
 - o Asco Power Products

5.17.11 Transfer Switches

1. References

- a. CAN3-C13, Instrument Transformers.
- b. CAN3-C17, Alternating-Current Electricity Metering.
- c. ANSI/NEMA ICS 2, Industrial Control Devices, Controllers, and Assemblies.

2. System Description

Automatic load transfer equipment which electrically operated, mechanically held to:

- a. Monitor voltage on all phases of normal power supply.
- b. Initiate cranking of standby generator unit via generator panel control unit, on normal power failure or abnormal voltage on any one phase below preset adjustable limits for adjustable period of time.
- c. Transfer load from normal supply to standby unit when standby unit reaches rated frequency and voltage pre-set adjustable limits.
- d. Transfer load from standby unit to normal power supply when normal power restored, confirmed by sensing of voltage on all phases above adjustable pre-set limit for adjustable time period.
- e. Shut down standby unit after running unloaded to cool down using adjustable time delay relay (3 to 30 min).
- f. A signal or a dry contact shall be provided with the ATS to monitor the electrical system. Once the ATS engaged to backup power (or alternate source from normal), the signal will transmit signal to our BMS for notification.

A manual bypass (drawnout type) should be provided as isolation switch that allows manual bypass of the normal and emergency source, i.e. double bypass, to ensure continued power to emergency circuits in the event of a switch failure or required maintenance. See below for bypass switch requirements.

3. Shop Drawing

- a. Submit completed shop drawings for review and approval before commencing project. Include:
 - i. Make, model and type.
 - ii. Load classification:
 - iii. Single line diagram showing controls and relays.
 - iv. Description of equipment operation including:
 - Automatic starting and transfer to standby unit and back to normal power.
 - Test control.
 - Manual control.
 - Automatic shutdown.



4. Operation and Maintenance Data

- a. Provide operation and maintenance data for automatic load transfer equipment for incorporation into manual specified in Section 16010 - Electrical General Requirements.
- b. Detailed instructions to permit effective operation, maintenance and repair.
- c. Technical data:
 - i. Schematic diagram of components controls and relays.
 - ii. Illustrated parts lists with parts catalogue numbers.
 - iii. Certified copy of factory test results.
 - iv. Certified copy of field test results.

5. Source Quality Control

- a. Complete equipment, including transfer mechanism, controls, relays and accessories factory assembled and tested in presence of Consultant.
- b. Tests:
 - i. Operate equipment both mechanically and electrically to ensure proper performance.
 - ii. Check selector switch, in all modes of operation Test, Auto, Manual, Engine Start and record results.
 - iii. Check voltage sensing and time delay relay settings.
 - iv. Check:
 - o Automatic starting and transfer of load on failure of normal power.
 - o Retransfer of load when normal power supply resumed.
 - o Automatic shutdown.
 - o In-phase monitor operation.

Products

6. Materials

- a. Meters: to CAN3-C17.
- b. Instrument transformers: to CAN3-C13.
- c. Contactors: to ANSI/NEMA ICS 2.

7. Contactor Type Transfer Equipment

- a. Two - 3 phase contactors mounted on common frame, in double throw arrangement, mechanically and electrically interlocked, motor solenoid operated, open type with CSA 1 enclosure.



- b. Transfer switch shall be drawout design that allows for easy maintenance.
 - c. Rated: 600V, 60 Hz, 4 wire, solid full rated neutral, amperage as indicated on drawings.
 - d. Main contacts: silver surfaced, protected by arc disruption means including separate arcing contacts, arc splitters and blow out coils for load current.
 - e. Switch and relay contacts, coils, spring and control elements accessible for inspection and maintenance from front of panel [without removal of switch panel or disconnection of drive linkages and power conductors].
 - f. Auxiliary contact shall be gold/silver-plated, to initiate emergency generator start-up on failure of normal power.
 - g. Fault withstand rating: 42kA symmetrical for 3 cycles with maximum peak value of 56kA.
 - h. Lever to operate switch manually when switch is isolated.
 - i. Overlapping neutral contacts were multiple transfer switches are fed from multiple normal power sources.
8. Controls
- a. Selector switch - four position "Test", "Auto", "Manual", "Engine start".
 - i. Test position - Normal power failure simulated. Engine starts and transfer takes place. Return switch to "Auto" to stop engine.
 - ii. Auto position - Normal operation of transfer switch on failure of normal power; retransfers on return of normal voltage and shuts down engine.
 - iii. Manual position - Transfer switch may be operated by manual handle but transfer switch will not operate automatically and engine will not start. If the transfer switch is on manual operation mode, a red light should indicate a warning on the control panel and auxiliary contact to be provided for transferring this signal to off site.
 - iv. Engine start position - Engine starts but unit will not transfer unless normal power supply fails. Switch must be returned to "Auto" to stop engine.
 - b. Control transformers: dry type with 120 V secondary to isolate control circuits from:
 - i. Normal power supply.
 - ii. Emergency power supply.
 - c. Relays: continuous duty, industrial control type, with wiping action contacts rated 10 A minimum:
 - i. Voltage sensing, one per phase for normal power and on one phase only for emergency, solid state type, adjustable drop out and pick up, close differential, 2 V minimum undervoltage and overvoltage protection. Voltage sensing to initiate transfer of the load when normal power supply drops to 70% in any phase and pick up at 90% on all phases.
 - ii. Time delay, normal power to standby, adjustable solid state, 0 seconds to 60



seconds.

- iii. Time delay on engine starting to override momentary power outages or dips, adjustable solid state, 1 to 60 seconds delay.
 - iv. Time delay on retransfer from standby to normal power, adjustable 3 to 30 mins.
 - v. Time delay for engine cool-off to permit standby set to run unloaded after retransfer to normal power, adjustable solid state, 20 seconds intervals to 10 mins.
 - vi. Time delay during transfer to stop transfer action in neutral position electrically to prevent fast transfer, adjustable, 5 second intervals to 180 seconds.
 - vii. Frequency sensing, to prevent transfer from normal power until supply until frequency of standby unit reaches preset adjustable values.
- d. Solid state electronic in-phase monitor.
 - e. Units to have overriding transfer control provision from Emergency generator control panel for load shedding purposes should one of the paralleling generators trip off line.

9. Accessories

- a. Pilot lights to indicate switch position, green for normal, red for standby, mounted in panel with remote capabilities.
- b. Solid neutral bar full rated.
- c. Overlapping neutral contacts on contactor type transfer equipment.
- d. Auxiliary relay to provide 2 N.O. and 2 N.C. contacts for remote alarms.
- e. Instruments:
 - i. Digital indicating type 2% accuracy, flush panel mounting:
 - o Voltmeter: ac.
 - o Ammeter: ac.
 - o Frequency meter.
- f. Voltmeter selector switch: panel mounting type.
- g. Potential transformers - dry type for indoor use:
 - i. Ratio: 600 to 120.
 - ii. Rating: 600V, 60 Hz, BIL 10kV.
 - iii. Accuracy rating: 2%.
- h. Ammeter selector switch: rotary, maintained contacts, panel mounting type, designed to prevent opening of current circuits, round notched handle, four position labelled "OFF - Phase A - Phase B - Phase C".
- i. Current transformers - dry type for indoor use:



- i. Ratio: As noted on drawings for different sizes.
- ii. Rating: 600V, 60 Hz, BIL 10kV.
- iii. Accuracy rating: 2%.
- iv. Positive action automatic short-circuiting device in secondary terminals.

10. Equipment Identification

- a. Provide equipment identification in accordance with Section 16010 - Electrical General Requirements.
- b. Control panel:
 - i. For selector switch and manual switch: size 5 nameplates.
 - ii. For meters, indicating lights, minor controls: size 3 nameplates.

11. Acceptable Manufacturers

- a. ASCO 7000 series.

Execution

12. Installation

- a. Locate, install and connect transfer equipment.
- b. Check relays and solid state monitors and adjust as required.
- c. Install and connect battery and remote alarms.

13. Field Quality Control

- a. Perform tests in accordance with Section 16980 - Testing, Adjusting and Balancing of Electrical Equipment and Systems.
- b. Energize transfer equipment from normal power supply.
- c. Set selector switch in "Test" position to ensure proper standby start, running, transfer, re-transfer. Return selector switch to "Auto" position to ensure standby shuts down.
- d. Set selector switch in "Manual" position and check to ensure proper performance.
- e. Set selector switch in "Engine start" position and check to ensure proper performance. Return switch to "Auto" to stop engine.
- f. Set selector switch in "Auto" position and open normal power supply disconnect. Standby should start, come up to rated voltage and frequency, and then load should transfer to standby. Allow to operate for [10] min, then close main power supply disconnect. Load should transfer back to normal power supply and standby should shutdown.
- g. Repeat, at 1 h intervals, 3 times, complete test with selector switch in each position, for each test.



5.17.12 Clean Power Systems

1. Uninterruptible Power Systems

- a. Uninterruptible power supplies need to be designed to protect electronic and critical systems in the event of a power outage.
- b. They need to be online conversion type and protect against the following events:
 - i. Electrical Noise
 - ii. Impulses and or spikes
 - iii. Momentary interruptions
 - iv. Flickers
 - v. Voltage dips or sags
 - vi. Swells
 - vii. Under voltage / brown outs
 - viii. Over voltages
 - ix. Power outages
 - x. Variation in Frequency
- c. Automatic voltage regulation is also to be incorporated into the UPS
- d. The UPS is to come complete with LCD display
- e. UPS can be of the rack mounted and or tower. (For UPS up to 2kVA in size, support UPS on a shelf near the equipment. Do not install UPS inside the equipment or in its cabinets due to the weight and heat generated. Mount UPS with the manufacturers rating plate visible when looking at units.)
- f. Batteries are to be of the sealed lead acid type and rechargeable. They also need to be hot swappable
- g. In some facilities technology/server room back-up systems may be designed by the tenant agency. If this is the case, shell space and utility rough-ins shall be provided. In facilities where uninterruptible power supply (UPS) systems are to be provided as part of the building construction, they shall be designed as described in this section. All UPS systems are considered to be above standard for U of C space. Tenant agencies with UPS requirements are advised that a maintenance contract is recommended.
- h. Requirements for UPS systems must be evaluated on a case by case basis. If UPS is required, it may or may not require generator back-up. When generator back-up is unnecessary, sufficient battery capacity shall be provided to allow for an orderly shut-down.
- i. The nature, size, and locations of critical loads to be supplied by the UPS will be provided in the program. The UPS system shall serve critical loads only. Non-critical loads shall



be served by separate distribution systems supplied from either the normal or electronic distribution system. All UPS systems shall be sized with 25 percent spare capacity. The specification of a redundant module shall depend upon the criticality of the loads.

- j. When the UPS is running on emergency power, the current to recharge the UPS batteries shall be limited. This limited battery charging load shall be added when sizing the emergency generator. If the UPS system is backed up by a generator to provide for continuous operation, the generator shall provide power to all necessary auxiliary equipment, i.e., the lighting, ventilation, and air conditioning supplying the UPS and the critical technical area.
- k. The UPS shall include all instruments and controls for proper system operation. The system status panel shall have an appropriate audio/visual alarm to alert operators of potential problems. It shall include the following monitoring and alarm functions: system on, system bypassed, system fault, out of phase utility fault, closed generator circuit breaker. It shall have an audible alarm and alarm silencer button. Since UPS equipment rooms are usually unattended, an additional remote system status panel must be provided in the space served by the UPS. The alarms shall also be transmitted to the BAS.
- l. Provide emergency lighting in both spaces. Provide a telephone in or adjacent to the UPS room. Battery room design must accommodate: proper ventilation, hydrogen detection, spill containment, and working clearances. Also, see the CEC for additional requirements.
- m. The UPS modules and associated batteries must be installed in separate, adjacent rooms. See the UPS and battery manufacturers' installation instructions for weights, dimensions, efficiency, and required clearances in the design. Allow space for storage of safety equipment, such as goggles and gloves. Special attention shall be given to floor loading for the battery room, entrance door dimensions for installation of the UPS and ceiling height for clearance of the appropriate HVAC systems and exhaust systems.
- n. The following manufacturers will be accepted
 - i. Liebert – GXT4
 - ii. APC Back –UPS PRO
 - iii. Powerware 9130

2. Computer Centre Power Distribution Unit

- a. In some U of C buildings the power distribution system for computer centres will be designed by the tenant agency. In that case, utility rough-in shall be provided under the construction contract. If distribution is to be provided under the building contract, it shall be designed according to the criteria in this section.
- b. Power Distribution Units (PDU's) with internal or remote isolation transformers and output panelboards shall be provided in all computer centres to reduce/eliminate harmonic currents generated by non-linear loads and reflected back to the neutral service conductors. Neutral busses/conductors shall be sized at 200% of phase busses/conductors. PDU's with internal or remote isolation transformers shall be K-rated to serve non-linear loads. The transformer rating must take the increased neutral size into account.



3. Computer Centre Grounding

- a. To prevent electrical noise from affecting computer system operation, a low-frequency power system grounding and a high-frequency signal reference grounding system shall be provided. The design of the technology/server room grounding system shall be discussed with the computer centre staff.

4. Low Frequency Power System Grounding

- a. The primary concern is to provide a safe, low-frequency, single point grounding system that complies with Section 10 of the CEC. The single point ground must be established to ground the isolation transformer or its associated main service distribution panel.
- b. A grounding conductor shall be run from the PDU isolation transformer to the nearest effective earth grounding electrode as defined in the CEC. All circuits serving Automated Data Processing (ADP) equipment from a PDU shall have grounding conductors equal in size to the phase conductors.

5. High Frequency Power System Grounding

- a. If requested by the User Agency, in addition to the low frequency power system grounding, a high frequency signal reference grounding system for radio frequency noise is required (with the two systems bonded together at one point). A grid made up of 600 mm squares will provide an effective signal reference grounding system. The raised floor grid may be used if it has mechanically bolted stringers. Alternatively, a grid can be constructed by laying a 600 mm squares mesh of braided copper strap or 1.3 mm (16 gauge) by 50 mm copper strap directly on the structural floor below the raised access floor. Data processing equipment shall be connected to the reference grid by the most direct route with a braided copper strap.

6. Common Mode Noise Reduction

- a. The reduction of common mode noise is particularly important for the proper operation of computer-based, distributed microprocessor-based systems, i.e., building automation systems, electronic security systems, card access control systems, and local area networks.
- b. The following guidelines shall be considered to reduce common mode noise:
 - i. Avoid running unshielded metallic signal or data lines parallel to power feeders.
 - ii. Where metallic signal or data lines must be routed in noise prone environments, use shielded cables or install wiring in ferrous metal conduit or enclosed cable trays.
 - iii. Locate metallic signal or data lines and equipment at a safe distance from arc producing equipment such as line voltage regulators, transformers, battery chargers, motors, generators, and switching devices.
 - iv. Provide isolation transformers, electronic power distribution panelboards or power conditioners to serve critical electronics equipment loads.
 - v. Provide isolated grounding service on dedicated circuits to critical data terminating or communicating equipment.

- vi. Replace metallic data and signal conductors with fibre optic cables where practical.
7. Harmonic Generation, K-Rated Transformers, Sizing of Neutrals
- a. Harmonic frequencies are introduced into the branch circuit distribution system by the power supplies of items or equipment like the following:
 - i. Electronic ballasts
 - ii. Variable Frequency Drives (VFDs)
 - iii. PC's
 - iv. Laser printers
 - v. File servers
 - vi. Fax machines
 - vii. Copiers
 - b. The third order harmonics (180 Hz) add in the neutral conductor and, in the case of 100 percent total harmonic distortion, would result in a neutral current of 1.73 times the phase current.
 - c. K-Rated Transformers (K-13) with a 200 percent neutral shall feed branch circuit panelboards with 200 percent neutrals.

5.17.13 Grounding Systems

- 1. General
 - a. Grounding systems shall be designed to coordinate with the specific type and size of the electrical distribution system, including the following applicable generic types of grounding systems, or grounding components:
- 2. Separate equipment ground conductors.
 - a. Comply with the CEC, Section 10, for types, sizes, and quantities of equipment grounding conductors, unless specific types, larger sizes, or more conductors than required by the CEC are indicated.
 - b. Install insulated equipment grounding conductor with circuit conductors for the following items, in addition to those required by CEC:
 - i. Feeders and branch circuits
 - ii. Lighting circuits
 - iii. Receptacle circuits
 - iv. Single-phase motor and appliance branch circuits
 - v. Three-phase motor and appliance branch circuits
 - vi. Flexible raceway runs

vii. Metal clad cable runs

3. Busway Supply Circuits

- a. Install insulated equipment grounding conductor from the grounding bus in the switchgear, switchboard, or distribution panel to equipment grounding bar terminal on busway.

4. Separately Derived Grounds

- a. Good practice dictates that, in order to minimize extraneous “noise” on certain systems, particularly those in which harmonics are generated; the specific system grounds shall be separated prior to grounding at the service grounding electrode or counterpoise.

5. Isolated Grounds

- a. Isolated grounds are applied where the equipment served may be particularly sensitive to external interference from sources generating third harmonics and higher. In these instances the grounds, beginning from the panelboard ground and the grounding conductor from the raceway to the grounding terminal at the receptacle or outlet box, shall be electrically isolated from the main grounding system. The isolated grounds shall terminate at a common ground or counterpoise.

6. Raised Floors

- a. Access floors shall be grounded. A grounding conductor shall be bonded to every other floor pedestal and shall be extended to the technology/server room common ground bus. The grounding conductor for these floors are to be sized according to the Canadian Electrical Code latest edition.

7. Counterpoise

- a. Where feasible, a grounding conductor (counterpoise) shall be provided in an isosceles triangle configuration with sides greater than or equal to 3 meters. The conductor shall be tinned copper not less than No. 3/0 AWG and shall be electrically connected to the incoming domestic water services on either side of the building as well as the various clusters of three (3) ground rods spaced at intervals. Ground rods shall be 15 mm diameter by 3 m long and shall be tin coated copper. The counterpoise loop will involve direct burial in earth 1.2 m min. below grade. The following items shall be connected to the counterpoise loop:

- i. Lightning protection system “down conductors”
- ii. Transformers in substations
- iii. Emergency generator ground
- iv. Telecom and data room grounds
- v. Separately derived grounds
- vi. Isolated ground panels
- vii. Main switchgears
- viii. Normal and emergency distribution systems

ix. Flagpoles

5.17.14 Lightning Protection Systems

1. General

- a. Lightning protection systems are important safety features in the design of electrical distribution systems. Their application on any specific project is a function of its geographic location, height, proximity of taller adjacent structures and the architectural configuration of the building. Professional involvement is required to meet code requirement and latest STANDATA. The decision to recommend a lightning protection system shall be made at the earliest stages of design and shall be supported by a study as prescribed by CAN/CSA-B72-M87 and NFPA 780.

2. Master Label

- a. If a decision is made to provide a lightning protection system, it shall be installed in compliance with CAN/CSA-B72:20 Standard. A CSA Master Label shall be required.

3. Alternate Systems

- a. The requirement of a “Master Label” imposes certain restrictions or limitations on the design of the system which may be in conflict with the architectural design, particularly if the façade includes large curved surfaces which preclude the installation of air terminals and where the spacing of down conductors are limited. In those instances the design engineer may appeal to the Contracting Officer to waive the “Master Label” requirement on the basis that the design generally follows the “Faraday Cage” principle of lightning protection.

4. Grounding

- a. The down conductors shall follow direct paths from the air terminals to ground connections or to the counterpoise loop.

5.17.15 Security Systems

1. Refer to Design Standard 5.19 Access Control and CCTV. The type and level of security system designed shall be determined by a security design professional and shall be commensurate to the threat evaluation of the facility. The system must be integrated into the design, if a new building, or provided for in a non-intrusive way, in the case of an existing building. The systems shall be provided with integral battery back-up and connected to the building emergency generator. The systems shall be compatible with the U of C Siemens security network and be reviewed and approved by Campus Security.

5.17.16 Short Circuit and Coordination Study

1. The design engineer shall submit a preliminary computer generated short circuit analysis on all projects. The final coordination and analysis shall be done by the contractor’s testing agency or by the independent agency employed by the client, and a report shall be submitted. Electronic data compatible with etap software shall also be submitted.

5.17.17 Spare Part List.

Service	Part	Quantity
Fans and pumps	Variable frequency drive	One (1) of each size
Miscellaneous	receptacles and switches	2% of total
Fuses - Low Voltage	Fuses above 600 A	Three (3) spare fuses of each type and size installed
	Fuses up to and including 600 A	Six (6) fuses of each type and size installed
Motor Starters to 600V	Control transformers	One (1)
	Operating coil	One (1)
	Control fuses	Two (2)
	Indicating lamp	One (1)
Exterior Emergency Power Generation	Fuses	One (1) spare set
Exit Lights	LED lamp cards for exit lighting fixtures	Two (2)
Lighting Equipment	Provide spare diffusers, lenses and louvers as indicated under	Three (3)
Replacement lamps and ballast	60-150 days of construction usage	10% of lamps involved
	151-250 days of construction usage	20% of lamps involved
	251-350 days of construction usage	50% of lamps involved
	351- 450 days of construction usage	100% of lamps involved
	451+ days of construction usage	All fixtures
	Spare lamps	2% of total installed
Starter (for each size and type)	Contacts - Stationary	Three (3)
	Contacts - Movable	Three (3)
	Contacts - Auxiliary	One (1)
	Control transformers	One (1)
	Operating coil	One (1)
	Fuses	Two (2)
	Indicating bulbs used	10%
	Spare starter c/w wrapper for each size used	One (1)
Elevator	Car telephone (per car)	One (1)

APPENDIX I

(VFD labelling)



VFD PRECAUTIONS

FAULT CLEARING

DO NOT SHUT POWER OFF. RECORD FAULT INFORMATION FROM DISPLAY, ON FAULT LOG SHEET. DO NOT PRESS THE RESET BUTTON UNLESS YOU ARE SURE THE CAUSE OF THE FAULT HAS BEEN REMOVED / REPAIRED. IF THE FAULT FAILS TO CLEAR OR YOU DO NOT KNOW THE CAUSE, CONTACT ELECTRICAL MAINTENANCE IMMEDIATELY AT 220-7555.

CAUTION

DO NOT SHUT OFF BEFORE STOPPING THE MOTOR AT THE V.F.D. CONTROL KEYPAD. IF A FAULT CONDITION HAS OCCURED, CONTACT ELECTRICAL MAINTENANCE AT 220-7555.

MAINTENANCE WORK PROCEDURE FOR MOTORS CONTROLLED BY A V.F.D.

- 1) ADVISE CONTROLS SHOP OF IMPENDING WORK ON UNIT.(220-7555)
- 2) STOP MOTOR AT V.F.D. CONTROL KEYPAD AND LOCKOUT THE MOTOR ISOLATION SWITCH (IF PRESENT)
- 3) TAG AND LOCKOUT MCC DISCONNECT SWITCH FOR EXTENDED OR ELECTRICAL MAINTENANCE.
- 4) TO RETURN TO SERVICE, REVERSE ABOVE PROCEDURE.

FILTER MAINTENANCE

- 1) DO NOT OPEN THE VFD ISOLATION SWITCH OR THE MOTOR ISOLATION SWITCH WHILE THE VFD IS RUNNING
- 2) ADVISE CONTROLS SHOP OF IMPENDING WORK ON UNIT(220-7555) AND REQUEST SHUTDOWN
- 3) STOP MOTOR AT V.F.D. CONTROL KEYPAD AND LOCKOUT THE MOTOR ISOLATION SWITCH (IF PRESENT).
- 4) PROCEED WITH FILTER WORK

Lamacoid Placement:

LAMACOID #1-"FAULT CLEARING"& "CAUTION" LABEL SHOULD BE PLACED ON THE DRIVE

REMAINING LAMACOIDS #2 and #3, SHOULD BE PLACED ON THE ISOLATION SWITCH(S) AND THE VFD ISOLATION SWITCH. CDP/MCC CELL, THE MOTOR

LAMACOID #2 – MAINTENANCE WORK PROCEDURE FOR MOTORS CONTROLLED BY A VFD.

LAMACOID # 3 – FILTER MAINTENANCE

LAMACOID COLOR TO BE RED WITH WHITE LETTERING. ADHESIVE TAPE ON BACK TO BE 100% COVERAGE.

SIZE OF LABELS TO BE READABLE AND TO FIT ON THE FRONT OF THE DRIVES.

NOTE:

FOR VFD'S THAT OPERATE PUMPS ONLY FILTER MAINTENANCE LABEL CAN BE OMITTED.

Revision History

Revision Date	Version	Description
Aug 2022	1.2	Baseline version
August 10, 2023	1.0	Added Revision History table to end of document and reset to Version 1.0.
September 7, 2023	2.0	Add local disconnect requirement to VFD, Update VFD enclosure and filter requirement, Panel backboard size reduced. Remove 50% light control for fluorescent fixture. ATS signal to BMS added. Delete receptacle for handsfree faucet. No splicing inside panel. General formatting updates, update Table of Contents.
May 27, 2024	3.0	Clarification added to 5.17.7.6e related to use of internal DC Link Reactor. Added WEG, US Motors and Marathon as acceptable motor manufacturers. Delete 5.17.8.13e related to color of CAT 5 & 5E cable.
August 9, 2024	4.0	Added Section 5.17.7.18(b) (Fire Alarm Systems) acceptable Smoke Sensor products and locations for use in Smoke/Fire Dampers
March 26, 2026	5.0	Update section 5.17.7.18 with clarification on smoke/fire damper indicators. Update 5.17.8.8/9 related to the use of LED lamps only. Clarification to section 5.17.8.13 related to lighting controls. Update to acceptable products for section 5.17.8.26 Parking, Roadway & Pathway lighting. Delete section 5.17.17 Electrical Metering. See new standard 5.24 Metering Systems for Campus Infrastructure.